

ANALYTICAL GAS GENERATORS & ACCESSORIES

INNOVATIVE SOLUTIONS FOR YOUR LAB



CONTACT US

We have a representative dedicated to your area of the world. See the back cover for your specific representative so that we may serve you best.



VICI DBS USA

tel: +1 713-263-6970
 fax: +1 713-263-6971
 email: infousa@vicidbs.com
 web: www.vicidbs.com
 mail: 7255 Langtry Street
 Houston, TX 77040

VICI AG INTERNATIONAL

tel: +41 (41) 925 62 00
 fax: +41 (41) 925 62 01
 email: info@vicidbs.com
 web: www.vicidbs.com
 mail: Parkstrasse 2
 6214 Schenkon, Switzerland

TABLE OF CONTENTS

Timeline	i
Company Profile	1
Why Gas Generators	2-3



HYDROGEN GENERATORS

Applications	5
Features	6
Unique Benefits	7
Cascading	7
Product Comparison	8-9
NM Plus Series	10-15
PG Plus Series	16-21
Rack Models	22-33
FID Stations	34-45
FID Towers	46-54
Zero Air Module Option	55



ZERO AIR GENERATORS

Applications	93
Features & Benefits	93
Product Comparison	93
GC Plus	94-97
GC Plus Rack	98-101
GT Plus Ultra	102-107



ACCESSORIES

Customization	109
PCB 1500 Series	110-113



NITROGEN GENERATORS

Applications	57
Features & Benefits	58
Product Comparison	59
Mistral Evolution Series	60-69
Whisper Series	70-81
HP Plus Tower Series	82-87
HP Plus Rack	88-91

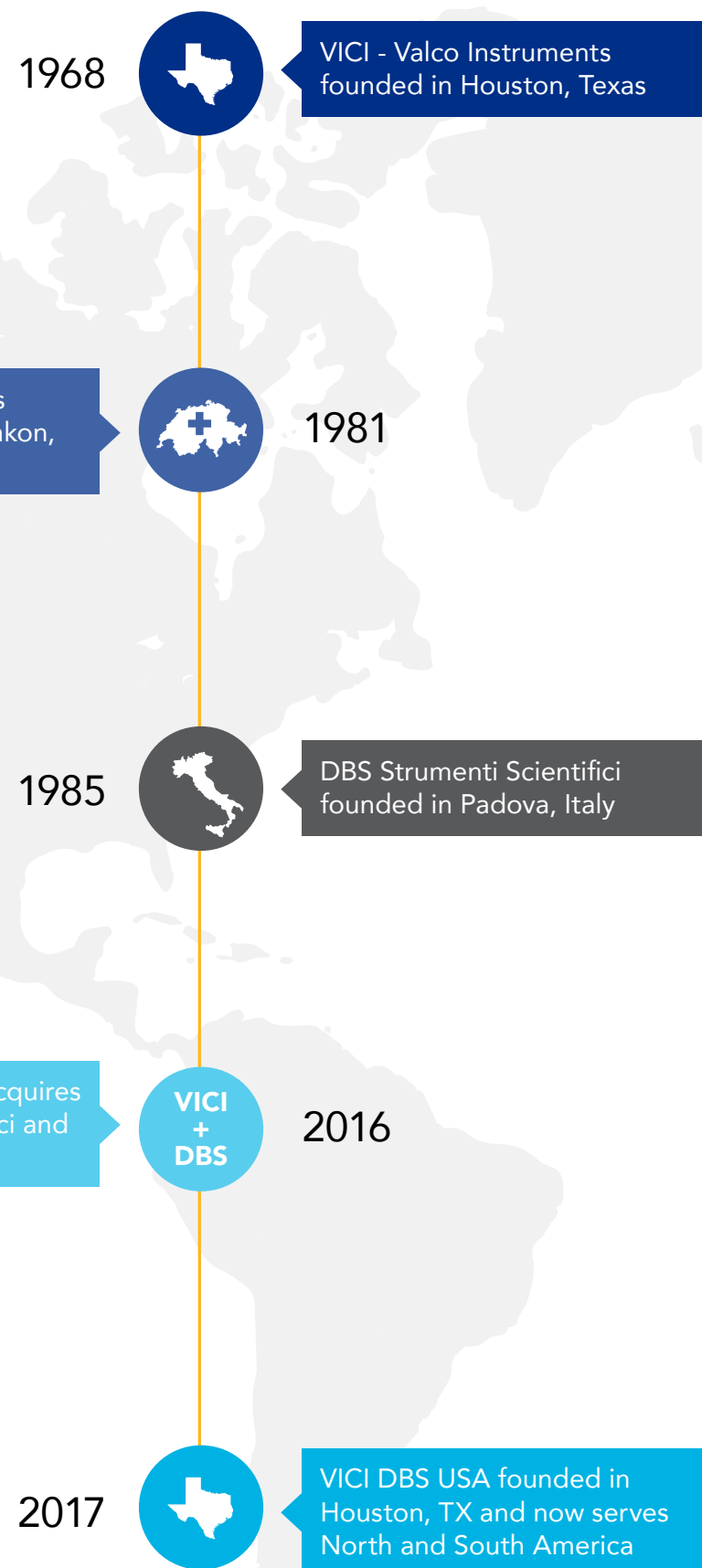

VICI DBS®

COMPANY PROFILE



VICI DBS® has been specializing in the design, development, and manufacturing of products and accessories for analytical instruments for over three decades.

DBS Strumenti Scientifici was founded in 1985 by former research assistants at the University of Padova. In 2016, DBS Strumenti Scientifici joined the VICI family of companies, becoming VICI DBS.

During its history, the company has grown from producing accessories based on specifications of researchers and manufacturers of analytical instruments, to becoming a market leader in the design and development of temperature control accessories for chemical analysis.

VICI DBS has also expanded its expertise beyond the field of temperature control, applying the latest electronic technology to develop a variety of specific applications for the analytical sector.

This evolution has culminated in the company developing new and innovative gas generators, using microprocessor control and patented designs to create products that are establishing themselves as benchmarks in their category.

Our modern facilities cover a total area of 1,500 square meters (16,146 square feet), and our specialist staff works together with a well-coordinated team of consultant engineers, software designers and specialist sub-contractors in the design and manufacturing of our product line, all in accordance with the UNI EN ISO 9001:2000 quality system.

WHY GAS GENERATORS

Gas generators offer a safe, convenient and cost-effective alternative to gas cylinders and dewars. A VICI DBS generator provides you with a dependable, easy to use and on-demand supply of ultra high-purity gas.



UNIVERSAL BENEFITS

- Eliminates dangerous high-pressure cylinders helping to keep your employees safer
- Removes the logistics, inconvenience, downtime, and costs of a cylinder system
- Flow capacity and purity to match your specific instrument demands
- Easy to install, operate and maintain
- Minimal maintenance - low cost of ownership
- Improve your workflow and productivity
- Superior gas purification
- Install directly in the laboratory



IMPROVE SAFETY

Gas is produced on demand, which allows for the safe use of the hydrogen generator when cylinders are prohibited or regarded as potentially dangerous. Sophisticated, easy to use software control and full alarm capability (including for hydrogen leaks) gives the user full control of the gas supply.



INCREASE EFFICIENCY

A constant gas supply with guaranteed purity eliminates interruptions of analysis to change cylinders and reduces the amount of instrument re-calibration required.



ENHANCE PERFORMANCE

Gas generators can be installed in the lab close to the instrument, eliminating the need for long gas lines from external cylinder supplies. A constant guaranteed high purity gas supply improves stability and ensures greater reproducibility of results.



RETURN ON INVESTMENT

The payback period can be as short as 6 to 12 months.



▶ TRUSTWORTHY TECHNOLOGY

VICI DBS is a leading innovator and manufacturer of high purity gas systems for analytical laboratories. Generators are specifically designed to exceed the stringent gas requirements for all the leading GC and LC/MS instrument manufacturers.

▶ ISO 9001:2015 CERTIFIED

Operating from our ISO 9001:2015 accredited gas generator manufacturing center in Italy, every VICI DBS product is designed and tested to ensure compliance with the relevant safety standards. All generators meet and exceed the requirements for CE, FCC, and MET (CSA and UL compliant).

▶ PATENTED TECHNOLOGY

Utilizing VICI DBS's range of patented proprietary technologies, there are 12,000 systems installed worldwide. These technologies offer unique performance benefits, including guaranteed ultra-high purity gas, silent operation, minimal moving parts and, minimal operator attention.



HYDROGEN GENERATORS

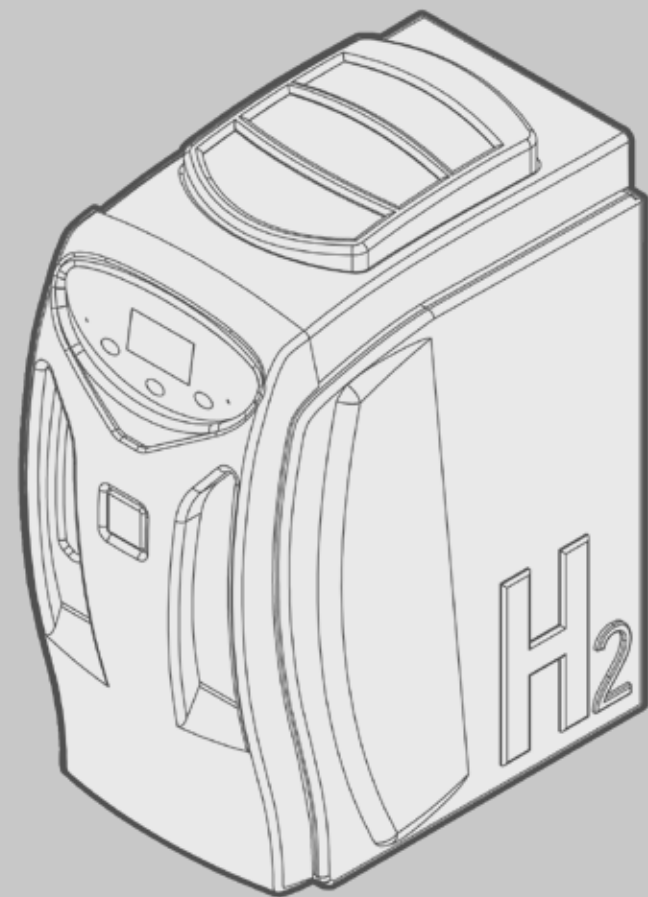

VICI DBS hydrogen generators offer the optimum combination of safe operation, reliability, and performance. Designed as a hazard-free alternative to high-pressure cylinders, all that is required is deionized water and a standard electrical supply for weeks of continuous operation.

Utilizing our proprietary Proton Exchange Membrane (PEM) inside a 100% titanium cell provides superior generator performance and cell longevity.

Innovative software control allows unrivaled operational performance and safety as well as the additional options of auto water feed, remote networking and cascading for built-in redundancy.

A sophisticated control system connected to an easy to use touch screen control continuously monitors vital operating parameters of the generator to ensure safe and consistent performance. Built-in sensors will shut the generator down if internal/external leaks are present, contaminated water, low water or overpressure.





FEATURES

- Produces a continuous supply of hydrogen
- On-demand supply 24/7
- Ideal for all GC detector applications
- PC monitoring for maintenance, diagnostics and remote connection
- Proprietary 100% titanium cell technology
- Unique permeation membrane drying system
- USB connectivity
- 2-year complete cell and product warranty
- Meets and exceeds the requirements for the most demanding GC applications



ENHANCED RESULTS

Hydrogen as a carrier gas is faster and more sensitive than expensive helium, with run time savings of 25% to 35% without a decline in resolution. The use of hydrogen as a carrier gas allows lower temperature elution, thus extending the life of the chromatograph column.



UNIQUE BENEFITS

- Superior hydrogen production with reliable long-life cell
- Cascading ability
- Zero Air Module option available for several units

WHAT IS CASCADING?

Cascading gas generators means connecting multiple gas generators together.

WHY WOULD YOU WANT TO CASCADE?

When you connect multiple gas generators together you are assured continuous production of hydrogen for your application.

Increase flow rate output up to 10 L/min. If you have greater needs for your application, the output can be increased significantly, permitting you to accomplish analyses that could not be accomplished with a lower flow rate.

HOW CASCADING WORKS:

The communication of the generators is done via an interface. Each generator needs to be assigned a unique ID number. Each generator must know how many generators are connected in the cascading group. As soon as the generators are powered up, one generator becomes the primary and controls the others (secondary). If there is a problem with the primary generator, one of the secondary generators will become the primary.

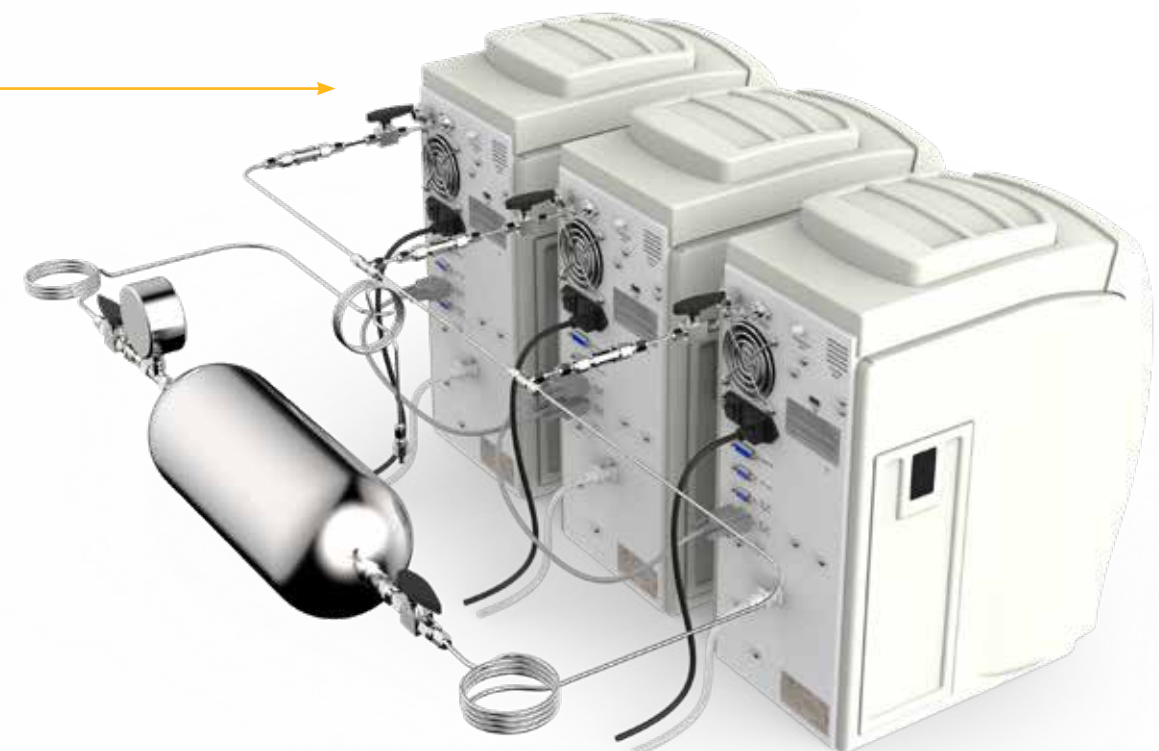
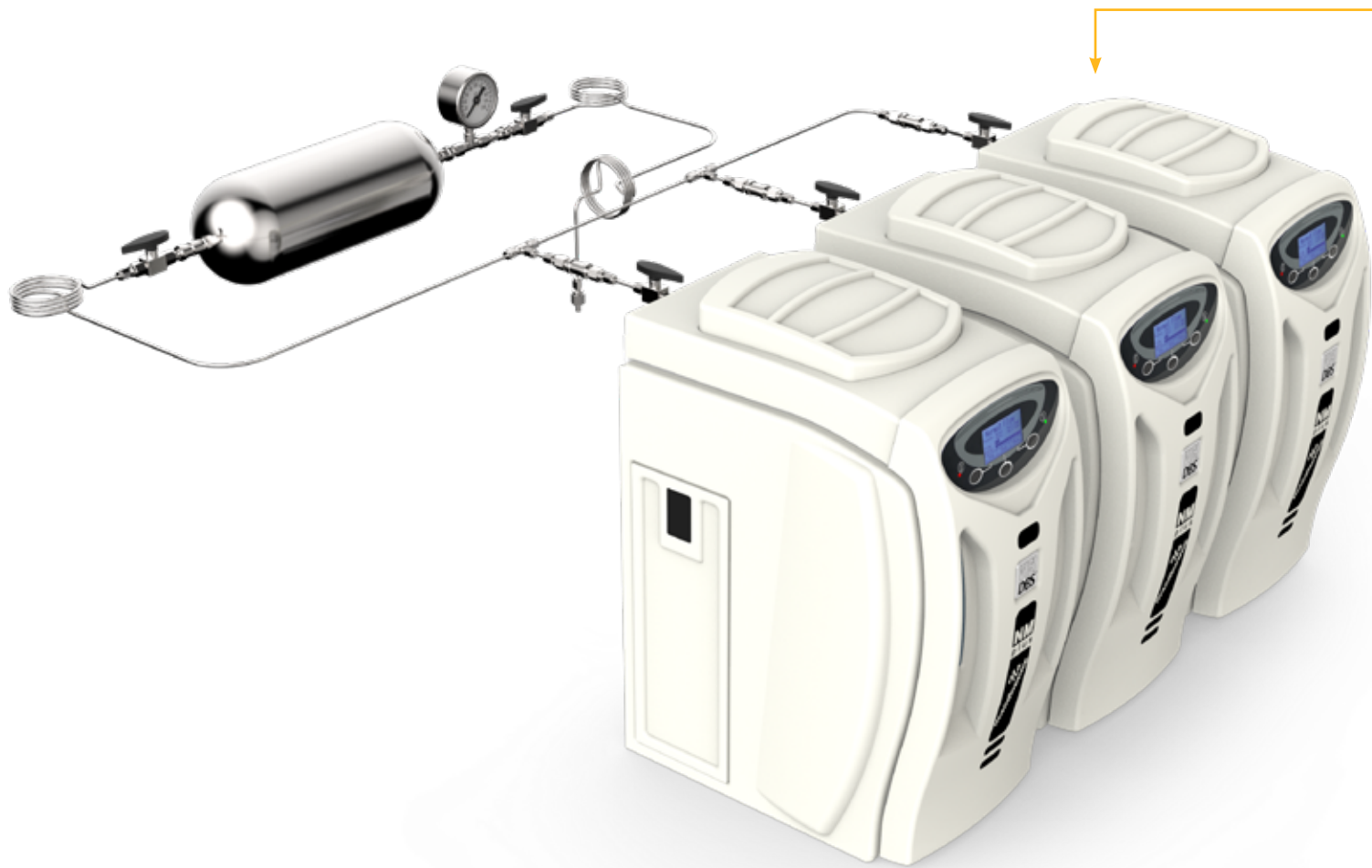

PRODUCT COMPARISON

	FLOW RATE	PURITY	PRESSURE - barg (psig)
NM PLUS 100	100 mL/min	>99.99996%	1.4 to 11 (20 to 160)
NM PLUS 160	160 mL/min	>99.99996%	1.4 to 11 (20 to 160)
NM PLUS 250	250 mL/min	>99.99996%	1.4 to 11 (20 to 160)
NM PLUS 300	300 mL/min	>99.99996%	1.4 to 11 (20 to 160)
NM PLUS 400	400 mL/min	>99.99996%	1.4 to 11 (20 to 160)
NM PLUS 500	500 mL/min	>99.99996%	1.4 to 11 (20 to 160)
NM PLUS 600	600 mL/min	>99.99996%	1.4 to 11 (20 to 160)
NM PLUS 1000	1000 mL/min	>99.99996%	1.4 to 11 (20 to 160)
NM PLUS 1350	1350 mL/min	>99.99996%	1.4 to 11 (20 to 160)
PG PLUS 100	100 mL/min	>99.9996%	0.5 to 11 (7 to 160)
PG PLUS 160	160 mL/min	>99.9996%	0.5 to 11 (7 to 160)
PG PLUS 250	250 mL/min	>99.9996%	0.5 to 11 (7 to 160)
PG PLUS 300	300 mL/min	>99.9996%	0.5 to 11 (7 to 160)
PG PLUS 500	500 mL/min	>99.9996%	0.5 to 11 (7 to 160)
PG PLUS 600	600 mL/min	>99.9996%	0.5 to 11 (7 to 160)
NM PLUS RACK 100	100 mL/min	>99.99996%	1.4 to 11 (20 to 160)
NM PLUS RACK 160	160 mL/min	>99.99996%	1.4 to 11 (20 to 160)
NM PLUS RACK 250	250 mL/min	>99.99996%	1.4 to 11 (20 to 160)
NM PLUS RACK 300	300 mL/min	>99.99996%	1.4 to 11 (20 to 160)
NM PLUS RACK 450	450 mL/min	>99.99996%	1.4 to 11 (20 to 160)
NM PLUS RACK 500	500 mL/min	>99.99996%	1.4 to 11 (20 to 160)
NM PLUS RACK 600	600 mL/min	>99.99996%	1.4 to 11 (20 to 160)
NM PLUS RACK 1000	1000 mL/min	>99.99996%	1.4 to 11 (20 to 160)
NM PLUS RACK 1350	1350 mL/min	>99.99996%	1.4 to 11 (20 to 160)
PG PLUS RACK 100	100 mL/min	>99.9996%	0.5 to 11 (7 to 160)
PG PLUS RACK 160	160 mL/min	>99.9996%	0.5 to 11 (7 to 160)

	FLOW RATE	PURITY	PRESSURE - barg (psig)
PG PLUS RACK 250	250 mL/min	>99.9996%	0.5 to 11 (7 to 160)
PG PLUS RACK 300	300 mL/min	>99.9996%	0.5 to 11 (7 to 160)
PG PLUS RACK 500	500 mL/min	>99.9996%	0.5 to 11 (7 to 160)
PG PLUS RACK 600	600 mL/min	>99.9996%	0.5 to 11 (7 to 160)
NM PLUS FID STATION 100	100 mL/min	>99.99996%	1.4 to 11 (20 to 160)
NM PLUS FID STATION 300	300 mL/min	>99.99996%	1.4 to 11 (20 to 160)
NM PLUS FID STATION 600	600 mL/min	>99.99996%	1.4 to 11 (20 to 160)
NM PLUS FID STATION 1000	1000 mL/min	>99.99996%	1.4 to 11 (20 to 160)
NM PLUS FID STATION 1350	1350 mL/min	>99.99996%	1.4 to 11 (20 to 160)
PG PLUS FID STATION 100	100 mL/min	>99.9996%	0.5 to 11 (7 to 160)
PG PLUS FID STATION 250	250 mL/min	>99.9996%	0.5 to 11 (7 to 160)
NM PLUS FID TOWER 100	100 mL/min	>99.99996%	1.4 to 11 (20 to 160)
NM PLUS FID TOWER 160	160 mL/min	>99.99996%	1.4 to 11 (20 to 160)
NM PLUS FID TOWER 250	250 mL/min	>99.99996%	1.4 to 11 (20 to 160)
NM PLUS FID TOWER 300	300 mL/min	>99.99996%	1.4 to 11 (20 to 160)
NM PLUS FID TOWER 500	500 mL/min	>99.99996%	1.4 to 11 (20 to 160)
NM PLUS FID TOWER 600	600 mL/min	>99.99996%	1.4 to 11 (20 to 160)
NM PLUS FID TOWER 1000	1000 mL/min	>99.99996%	1.4 to 11 (20 to 160)
NM PLUS FID TOWER 1350	1350 mL/min	>99.99996%	1.4 to 11 (20 to 160)
PG PLUS FID TOWER 100	100 mL/min	>99.9996%	0.5 to 11 (7 to 160)
PG PLUS FID TOWER 160	160 mL/min	>99.9996%	0.5 to 11 (7 to 160)
PG PLUS FID TOWER 250	250 mL/min	>99.9996%	0.5 to 11 (7 to 160)
PG PLUS FID TOWER 300	300 mL/min	>99.9996%	0.5 to 11 (7 to 160)
PG PLUS FID TOWER 500	500 mL/min	>99.9996%	0.5 to 11 (7 to 160)
PG PLUS FID TOWER 600	600 mL/min	>99.9996%	0.5 to 11 (7 to 160)



NM PLUS HYDROGEN GENERATOR

CARRIER GRADE



FLOW RATE:
100 to 1350 mL/min



PURITY:
>99.99996%



PRESSURE:
1.4 to 11 barg (20 to 160 psig)



TECHNOLOGY:
Proton Exchange Membrane (PEM) - 100% Titanium Cell



DESCRIPTION

The VICI DBS NM Plus hydrogen generator offers the optimum combination of safe operation, reliability, and performance. The permeation membrane drying system eliminates the requirement for desiccant cartridges along with the associated downtime and cost. The final purification stage uses a no maintenance cold dual dynamic regeneration system which increases the purity to >99.99996%. Innovative software control allows unrivaled operational performance and safety as well as the additional options of auto water feed, remote networking and cascading for built-in redundancy.

With a maximum output capacity of 1350 mL/min, one generator can supply up to 33 GCs. The compact design allows the generator to be installed directly in the laboratory eliminating the requirement for long gas lines and guaranteeing the delivery of high purity gas to your instruments.



APPLICATIONS

GC APPLICATIONS

- GC carrier gas
- GC/MS carrier gas
- GC fuel gas
- GC-ELCD & HALL reaction gas

ANALYZER APPLICATIONS

- Total Hydrocarbon Analyzer (THA) fuel gas
- Chemisorption/Physisorption measurement gas

SPECTROSCOPY APPLICATIONS

- ICP-MS collision cell reaction gas

OTHER APPLICATIONS

- Chemical vapor deposition (CVD) instrumentation aid deposition process
- Plasma cleaning instrumentation (UCP)
- High Efficiency process gas
- Hydrogenation reactor
- Hydrogen fuel cells
- Weather balloon filling
- Electronic Nose (eNOSE)
- 3-D Chromatography

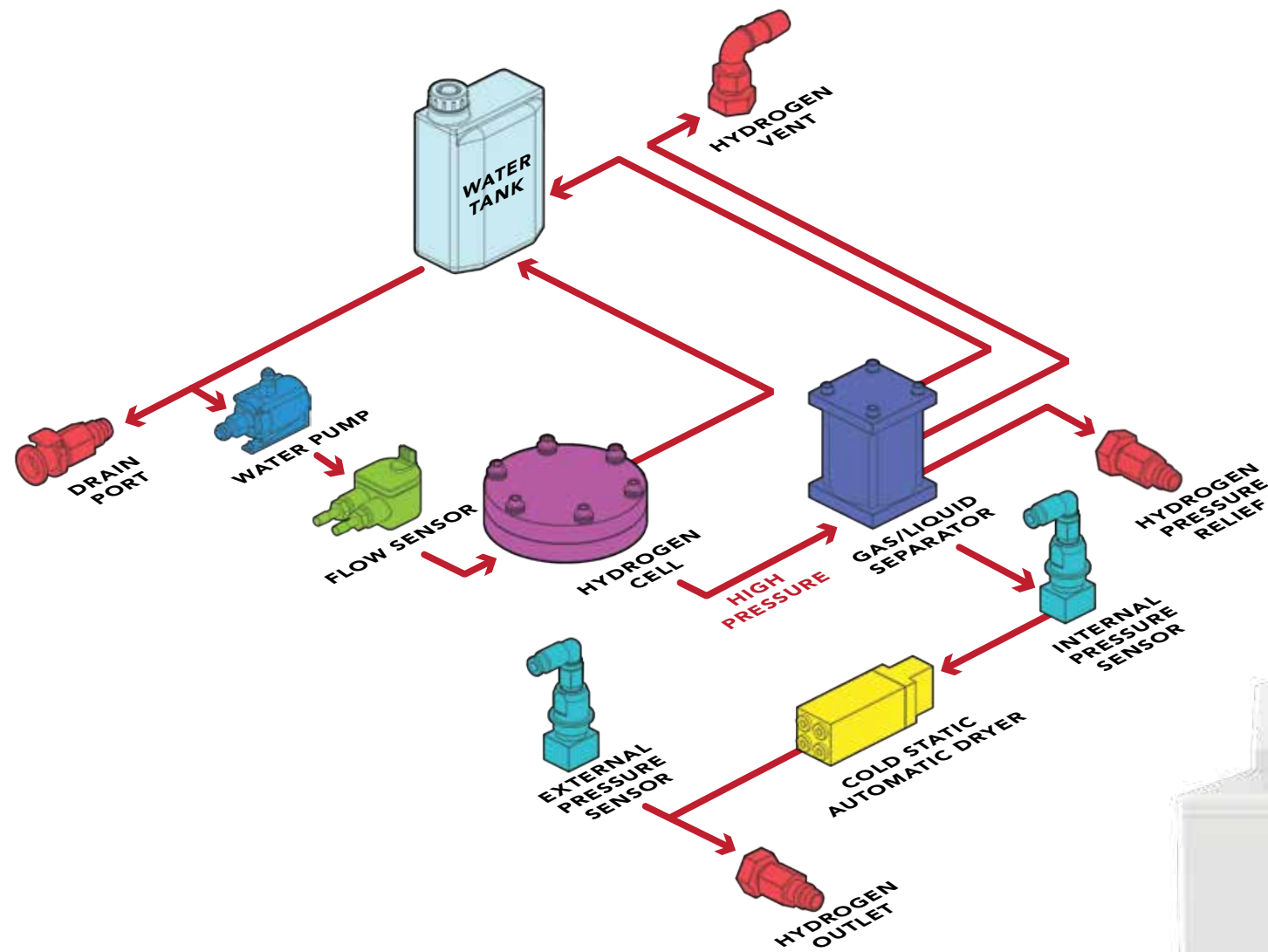

OPTIONS

- I/O board
- Remote control software (RS232 or USB)
- Cascading hardware & cables
- Automatic water refill
- On/Off and non-return valve (high purity)
- Buffer reservoir
- Pressure regulator with pressure gauge

OPERATING DIAGRAM

Hydrogen is produced from the hydrolysis of deionized water across a proton exchange membrane (PEM), housed in a 100% titanium cell. The output hydrogen is dried via a dual-stage process, a gas/liquid separator and an exclusive cold static automatic drying system. In addition to water, all that the generator requires is a standard connection and supply of electricity for a continuous 24/7 supply of high purity hydrogen. Consumable items are limited to the replacement of a deionizer bag every six months.



MODELS & SPECS

	NM PLUS 100	NM PLUS 160	NM PLUS 250	NM PLUS 300	NM PLUS 400	NM PLUS 500	NM PLUS 600	NM PLUS 1000	NM PLUS 1350
Flow mL/min	100	160	250	300	400	500	600	1000	1350
Purity	>99.99996%								
Dew point at 7 barg (100 psig)	-73 °C (-103 °F)								
Outlet pressure barg (psig)	1.4 to 11 (20 to 160)								
Technology	PEM (Proton Exchange Membrane) - 100% Titanium cell								
Drying system	No Maintenance Cold Dual Dynamic Regeneration System								
Deionized water quality	Minimum <1 micro S/cm @25°C - 1 Mohm-cm@25°C - ASTM II Recommended <0.2 microS/cm @25°C - 5 Mohm-cm @25°C - ASTM II								
Internal water tank liters	2.5								
Safety	Automatic shut down - internal/external hydrogen leak, overpressure, and low water								
Display	Touch screen with operating parameters, system status, and safety alarms								
LED indicators	Power on/off, system ready, errors								
Interface	USB mod A								
Electrical supply	110-120V 60Hz / 220-240V 50Hz								
Power consumption watts	100	120	165	205	210	220	255	385	410
Dimensions mm (in)	230W x 507H x 370D (9W x 19H x 15D)								
Weight kg (lb)	14 (31)	14 (31)	15 (33)	15 (33)	15 (33)	16 (35)	16 (35)	17 (37.5)	18 (39.5)
Shipping dimensions mm (in)	580W x 570H x 400D (22.8W x 22.4H x 15.7D)								
Shipping weight kg (lb)	18 (39.5)	18 (39.5)	19 (42)	19 (42)	19 (42)	20 (44)	20 (44)	21 (46)	22 (48)
Operating temp °C (°F)	15 to 35 (59 to 95)								
Outlet connection	1/8" Compression								
Certification	CE, FCC, MET (UL and CSA compliant)								

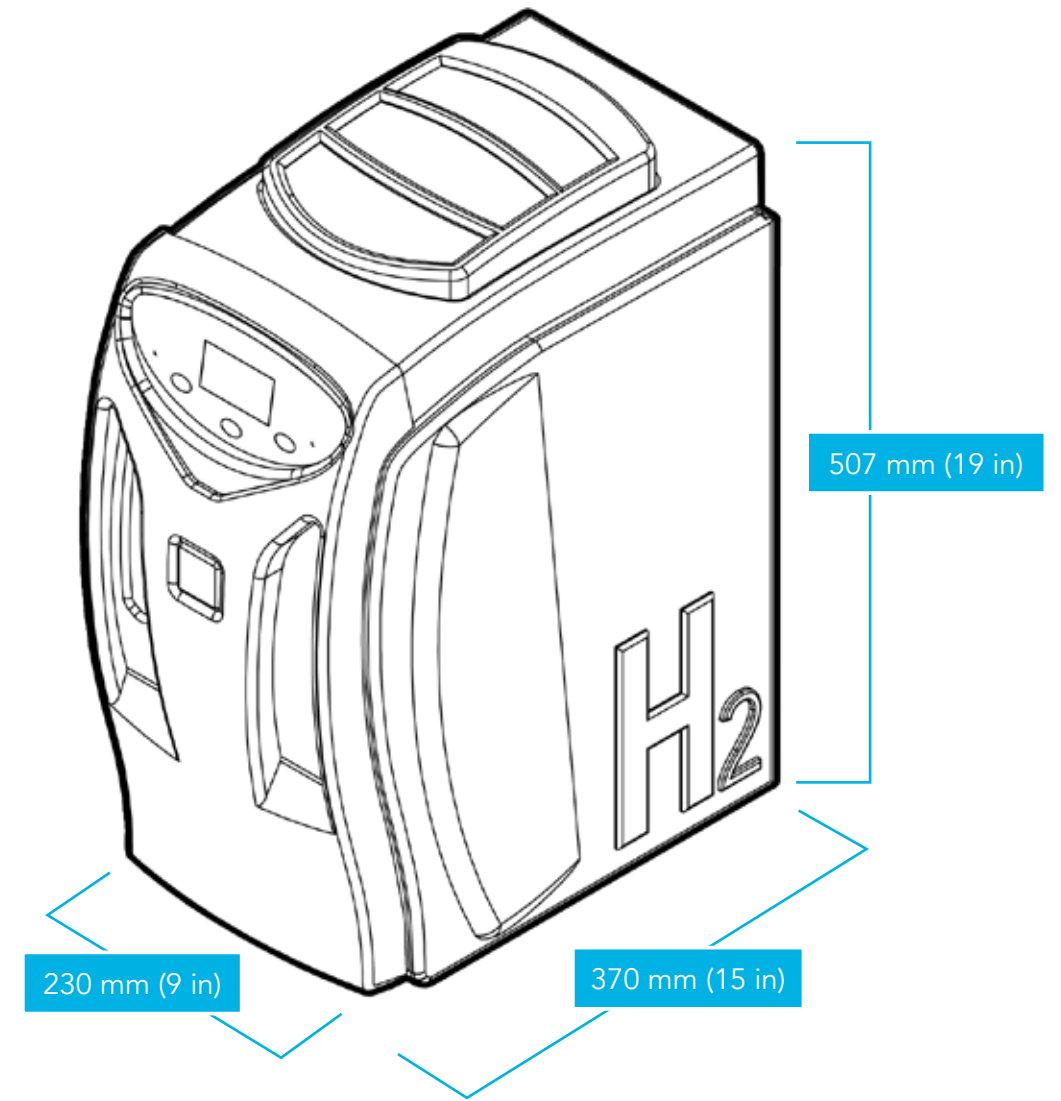

OPTIONS:

DB-10154	I/O BOARD FOR NM PLUS & PG PLUS
DB-10157	CABLE FOR CASCADING (I/O REQ)
DB-PH200-107	REMOTE RS232 (I/O REQ)
DB-PH200-108	REMOTE USB
DB-PH200-109	AUTOREFILL PLUS (I/O REQ)
DB-CASC-001	CASCADING HARDWARE KIT

DB-CASC-002	ON/OFF & NON-RETURN VALVE
DB-CASC-003	BUFFER RESERVOIR .75 LITERS
DB-CASC-004	PR WITH PRESSURE GAUGE
DB-CASC-005	CASCADING HARDWARE KIT (HP)
DB-CASC-006	PR WITH PRESSURE GAUGE (HP)

CONSUMABLES:

DB-H200-031	DEIONIZER LE BAG (PACK OF 2 PCS.)
--------------------	-----------------------------------

ORDERING INFORMATION (for best service, please call to discuss your application before placing your order).

NM PLUS 100

DB-PNM100-EU	230-240V/50-60Hz
DB-PNM100-US	115V/60Hz
DB-PNM100-JP	100V/60Hz

NM PLUS 160

DB-PNM160-EU	230-240V/50-60Hz
DB-PNM160-US	115V/60Hz
DB-PNM160-JP	100V/60Hz

NM PLUS 250

DB-PNM250-EU	230-240V/50-60Hz
DB-PNM250-US	115V/60Hz
DB-PNM250-JP	100V/60Hz

NM PLUS 300

DB-PNM300-EU	230-240V/50-60Hz
DB-PNM300-US	115V/60Hz
DB-PNM300-JP	100V/60Hz

NM PLUS 400

DB-PNM400-EU	230-240V/50-60Hz
DB-PNM400-US	115V/60Hz
DB-PNM400-JP	100V/60Hz

NM PLUS 500

DB-PNM500-EU	230-240V/50-60Hz
DB-PNM500-US	115V/60Hz
DB-PNM500-JP	100V/60Hz

NM PLUS 600

DB-PNM600-EU	230-240V/50-60Hz
DB-PNM600-US	115V/60Hz
DB-PNM600-JP	100V/60Hz

NM PLUS 1000

DB-PNM1000-EU	230-240V/50-60Hz
DB-PNM1000-US	115V/60Hz
DB-PNM1000-JP	100V/60Hz

NM PLUS 1350

DB-PNM1350-EU	230-240V/50-60Hz
DB-PNM1350-US	115V/60Hz
DB-PNM1350-JP	100V/60Hz



PG PLUS HYDROGEN GENERATOR

DETECTOR GRADE



FLOW RATE:
100 to 600 mL/min



PURITY:
>99.9996%



PRESSURE:
0.5 to 11 barg (7 to 160 psig)



TECHNOLOGY:
Proton Exchange Membrane (PEM) - 100% Titanium Cell



DESCRIPTION

The VICI DBS PG Plus offers the optimum combination of safe operation, reliability, and performance. The unique high-pressure permeation membrane drying system eliminates the requirement for desiccant cartridges along with the associated downtime and cost. Innovative software control allows unrivaled operational performance and safety as well as the additional options of auto water feed, remote networking and cascading for built-in redundancy.

With a maximum output capacity of 600 mL/min, one generator can supply up to 14 GCs. The compact design allows the generator to be installed directly in the laboratory eliminating the requirement for long gas lines and guaranteeing the delivery of high purity gas to your GC detectors.



APPLICATIONS

GC APPLICATIONS

- GC-FID fuel gas
- GC-NPD plasma gas
- GC-FPD fuel gas

ANALYZER APPLICATIONS

- Total Hydrocarbon Analyzer (THA) fuel gas

OTHER LAB APPLICATIONS

- Hydrogenation reactors
- Hydrogen fuel cells

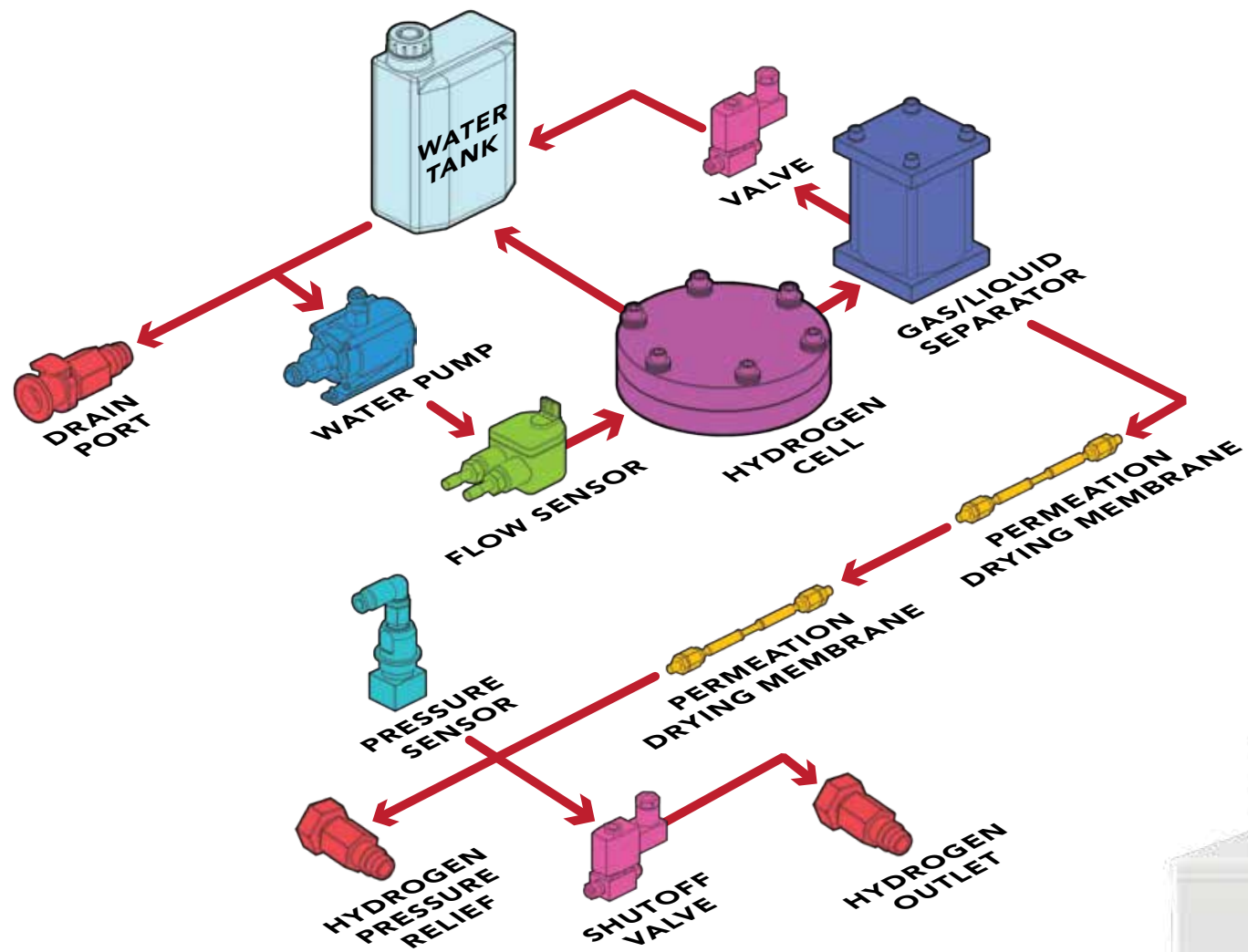

OPTIONS

- I/O board
- Remote control software (RS232 or USB)
- Cascading hardware & cables
- Auto refill plus, tubing & extension
- On/Off and non-return valve (high purity)
- Buffer reservoir
- Pressure regulator with pressure gauge

OPERATING DIAGRAM

Hydrogen is produced from the hydrolysis of deionized water across a PEM (proton exchange membrane), housed in a 100% titanium cell. The resultant hydrogen is dried via a dual-stage process, a gas/liquid separator and a unique dual high-performance permeation membrane dryer. In addition to water, all that the generator requires is a standard connection and supply of electricity for a continuous 24/7 supply of high purity hydrogen. Consumable items are limited to the replacement of a deionizer bag every 6 months.



MODELS & SPECS

	PG PLUS 100	PG PLUS 160	PG PLUS 250	PG PLUS 300	PG PLUS 500	PG PLUS 600
Flow mL/min	100	160	250	300	500	600
Purity	>99.9996%					
Dew point at 7 barg (100 psig)	-25 °C (-77 °F)					
Outlet pressure barg (psig)	0.5 to 11 (7 to 160)					
Technology	PEM (Proton Exchange Membrane) - 100% Titanium cell					
Drying system	Regenerative Permeation Membrane					
Deionized water quality	Minimum <1 micro S/cm @25°C - 1 Mohm-cm@25°C - ASTM II Recommended <0.2 microS/cm @25°C - 5 Mohm-cm @25°C - ASTM II					
Internal water tank liters	2.5					
Safety	Automatic shut down - internal/external hydrogen leak, overpressure, and low water					
Display	Touch screen with operating parameters, system status, and safety alarms					
LED indicators	Power on/off, system ready, errors					
Interface	USB mod A					
Electrical supply	110-120V 60Hz / 220-240V 50Hz					
Power consumption watts	75	95	140	180	190	230
Dimensions mm (in)	230W x 507H x 370D (9W x 19H x 15D)					
Weight kg (lb)	13 (28.5)	13 (28.5)	13 (28.5)	14 (31)	15 (33)	15 (33)
Shipping dimensions mm (in)	580W x 570H x 400D (22.8W x 22.4H x 15.7D)					
Shipping weight kg (lb)	17 (37.5)	17 (37.5)	17 (37.5)	18 (39.5)	19 (42)	19 (42)
Operating temp °C (°F)	15 to 35 (59 to 95)					
Outlet connection	1/8" Compression					
Certification	CE, FCC, MET (UL and CSA compliant)					

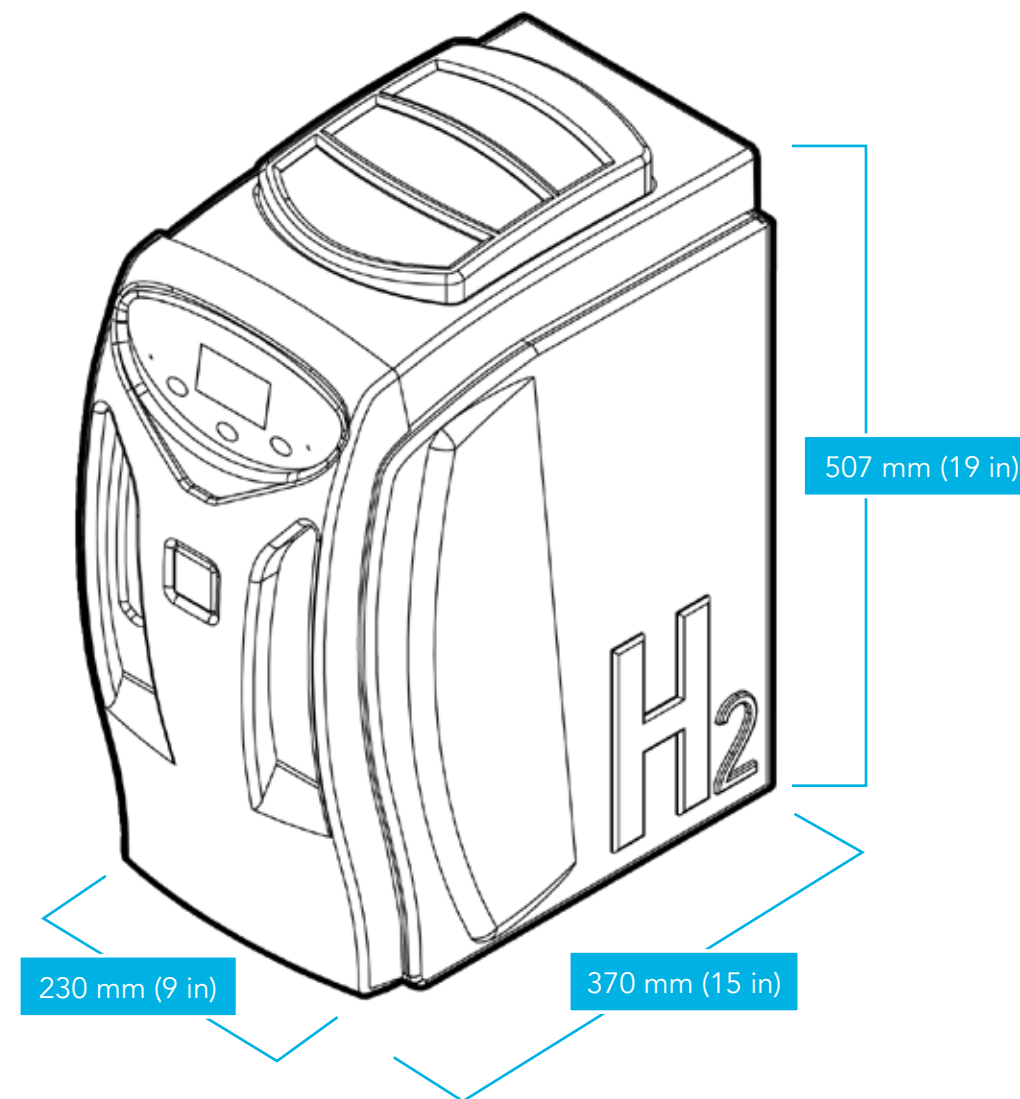

OPTIONS:

DB-10154 I/O BOARD FOR NM PLUS & PG PLUS
DB-10157 CABLE FOR CASCADING (I/O REQ)
DB-PH200-107 REMOTE RS232 (I/O REQ)
DB-PH200-108 REMOTE USB
DB-PH200-109 AUTOREFILL PLUS (I/O REQ)
DB-CASC-001 CASCADING HARDWARE KIT

DB-CASC-002 ON/OFF & NON-RETURN VALVE
DB-CASC-003 BUFFER RESERVOIR .75 LITERS
DB-CASC-004 PR WITH PRESSURE GAUGE
DB-CASC-005 CASCADING HARDWARE KIT (HP)
DB-CASC-006 PR WITH PRESSURE GAUGE (HP)

CONSUMABLES:

DB-H200-031 DEIONIZER LE BAG (PACK OF 2 PCS.)

ORDERING INFORMATION (for best service, please call to discuss your application before placing your order).

PG PLUS 100

DB-PHG100-EU 230-240V/50-60Hz
DB-PHG100-US 115V/60Hz
DB-PHG100-JP 100V/60Hz

PG PLUS 160

DB-PHG160-EU 230-240V/50-60Hz
DB-PHG160-US 115V/60Hz
DB-PHG160-JP 100V/60Hz

PG PLUS 250

DB-PHG250-EU 230-240V/50-60Hz
DB-PHG250-US 115V/60Hz
DB-PHG250-JP 100V/60Hz

PG PLUS 300

DB-PHG300-EU 230-240V/50-60Hz
DB-PHG300-US 115V/60Hz
DB-PHG300-JP 100V/60Hz

PG PLUS 500

DB-PHG500-EU 230-240V/50-60Hz
DB-PHG500-US 115V/60Hz
DB-PHG500-JP 100V/60Hz

PG PLUS 600

DB-PHG600-EU 230-240V/50-60Hz
DB-PHG600-US 115V/60Hz
DB-PHG600-JP 100V/60Hz



NM PLUS RACK HYDROGEN GENERATOR

+ ZERO AIR OPTION

CARRIER GRADE



FLOW RATE:
100 to 1350 mL/min



PURITY:
>99.99996%



PRESSURE:
1.4 to 11 barg (20 to 160 psig)



TECHNOLOGY:
Proton Exchange Membrane (PEM) - 100% Titanium Cell



DESCRIPTION

The VICI DBS NM Plus Rack combines the reliability of the hydrogen generator with an optional zero air generator into a 19" rack. The generator can be installed in any suitable 19" static or mobile cabinet. This simple but effective instrument can supply all your FID gas and carrier gas requirements.

With a maximum output capacity of 1350 mL/min, one generator can supply up to 33 FIDs. The compact design allows the generator to be installed directly in the laboratory eliminating the requirement for long gas lines and guaranteeing the delivery of high purity gas to your instrument.

Compressed air is prefiltered then purified using a state of the art combined heated catalyst module. The resultant air is free from total hydrocarbons to <0.1 ppm, making it ideal for all FID applications. These levels assure high sensitivity, a flat stable baseline, and no ghost peaks.



APPLICATIONS

ANALYZER APPLICATIONS

- Process GC analyzers detector fuel, oxidant gas
- Emissions test analyzers fuel gas, oxidant gas
- Stack gas analyzers fuel gas, oxidant gas

OTHER LAB APPLICATIONS

- On-board gas supply for mobile laboratories

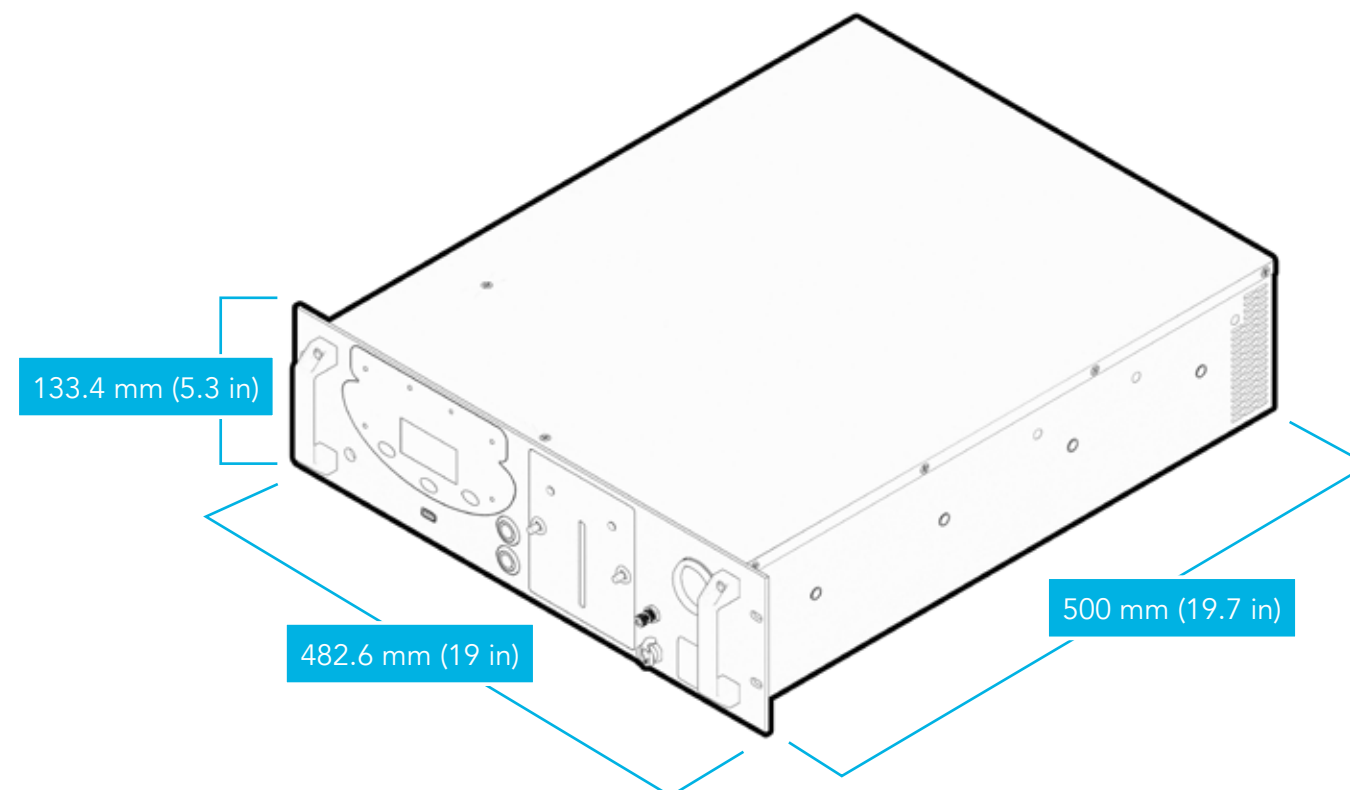

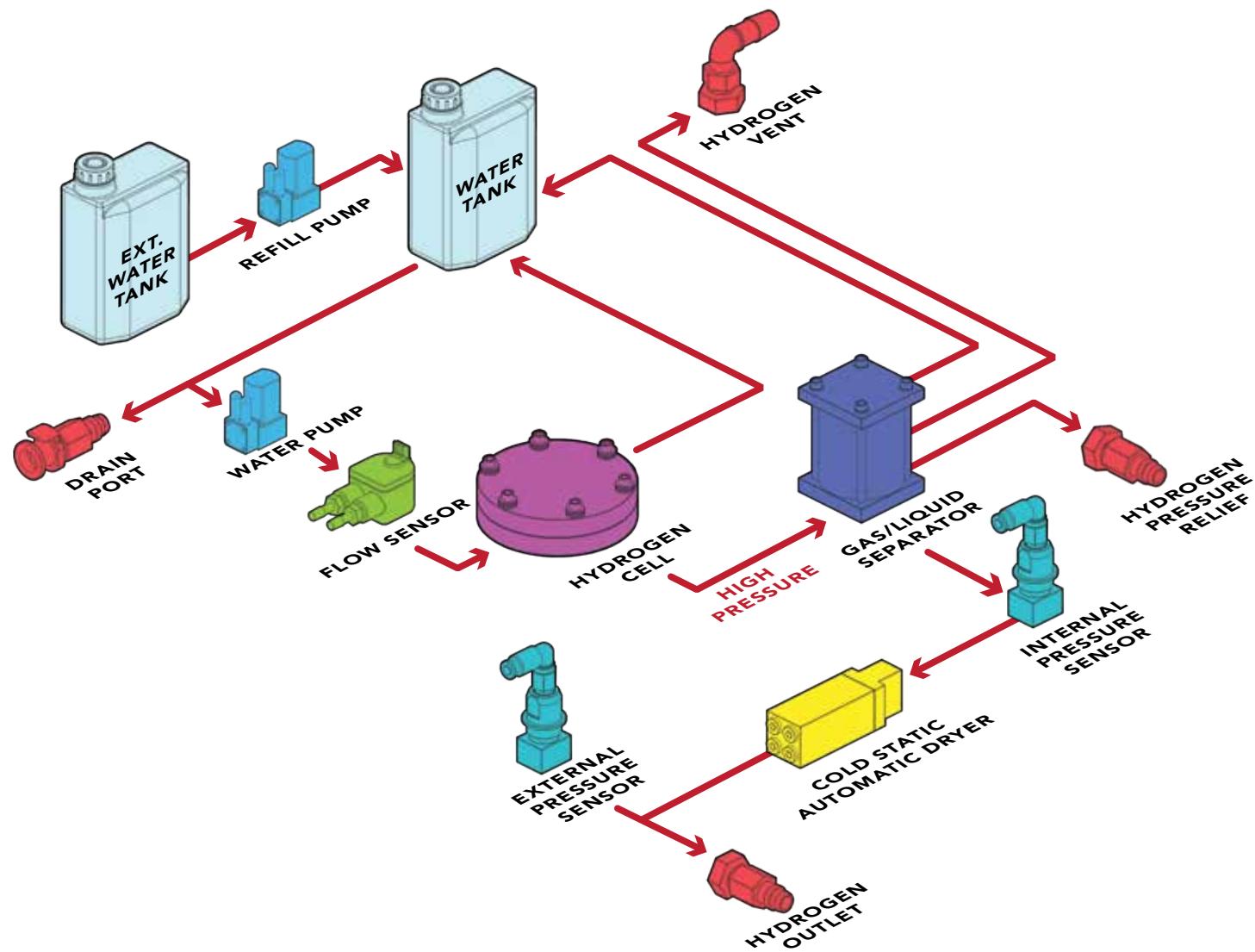

OPERATING DIAGRAM

Hydrogen is produced from the hydrolysis of deionized water across a PEM (proton exchange membrane), housed in a 100% titanium cell. The output hydrogen is dried via a dual stage process, a gas liquid separator and an exclusive cold static automatic drying system. In addition to water all that the generator requires is a standard connection and supply of electricity for a continuous 24/7 supply of high purity hydrogen. Consumable items are limited to the replacement of a deionizer bag every six months.



ZERO AIR OPTION

This model has a Zero Air option.
See page 55 for information and specifications.



OPTIONS

- I/O board
- Remote control software (RS232 or USB)
- Cascading hardware & cables
- Refill valve and station
- H₂ pipe fitting kit
- On/Off and non-return valve (high purity)
- Buffer reservoir (high purity)
- Pressure regulator with pressure gauge
- Zero Air option



MODELS & SPECS	NM PLUS 100 RACK	NM PLUS 160 RACK	NM PLUS 250 RACK	NM PLUS 300 RACK	NM PLUS 450 RACK
Flow mL/min	100	160	250	300	450
Purity	>99.99996%				
Dew point at 7 barg (100 psig)	73 °C (-103 °F)				
Outlet pressure barg (psig)	1.4 to 11 (20 to 160)				
Technology	PEM (Proton Exchange Membrane) - 100% Titanium cell				
Drying system	Triple drying system: gas/liquid separator, permeation membrane, and cold dual dynamic regeneration system				
Deionized water quality	Minimum <1 micro S/cm @25°C - 1 Mohm-cm@25°C - ASTM II Recommended <0.2 microS/cm @25°C - 5 Mohm-cm @25°C - ASTM II				
External water tank liters	External 10 liter bottle and internal pump				
Safety	Automatic shut down - internal/external hydrogen leak, overpressure, and low water				
Display	Touch screen with operating parameters, system status, and safety alarms				
LED indicators	Power on/off, system ready, errors				
Interface	USB mod A				
Electrical supply	110-120V 60Hz / 220-240V 50Hz				
Power consumption watts	90	115	125	150	180
Dimensions mm (in)	19" rack W x 3U H x 500D (19W x 5.25H x 19.68D)				
Weight kg (lb)	19 (41.9)		21 (46.2)		
Shipping dimensions mm (in)	720W x 375H x 565D (28.3W x 14.7H x 22.2D)				
Shipping weight kg (lb)	23 (50)		25 (55)		
Operating temp °C (°F)	15 to 35 (59 to 95)				
Outlet connection	1/8" Compression				
Certification	CE, FCC, MET (UL and CSA compliant)				

MODELS & SPECS	NM PLUS 500 RACK	NM PLUS 600 RACK	NM PLUS 1000 RACK	NM PLUS 1350 RACK
Flow mL/min	500	600	1000	1350
Purity	>99.99996%			
Dew point at 7 barg (100 psig)	73 °C (-103 °F)			
Outlet pressure barg (psig)	1.4 to 11 (20 to 160)			
Technology	PEM (Proton Exchange Membrane) - 100% Titanium cell			
Drying system	Triple drying system: gas/liquid separator, permeation membrane, and cold dual dynamic regeneration system			
Deionized water quality	Minimum <1 micro S/cm @25°C - 1 Mohm-cm@25°C - ASTM II Recommended <0.2 microS/cm @25°C - 5 Mohm-cm @25°C - ASTM II			
External water tank liters	External 10 liter bottle and internal pump			
Safety	Automatic shut down - internal/external hydrogen leak, overpressure, and low water			
Display	Touch screen with operating parameters, system status, and safety alarms			
LED indicators	Power on/off, system ready, errors			
Interface	USB mod A			
Electrical supply	110-120V 60Hz / 220-240V 50Hz			
Power consumption watts	200	300	400	500
Dimensions mm (in)	19" rack W x 3U H x 500D (19W x 5.25H x 19.68D)			
Weight kg (lb)	21 (46.2)		22 (48.5)	
Shipping dimensions mm (in)	720W x 375H x 565D (28.3W x 14.7H x 22.2D)			
Shipping weight kg (lb)	25 (55)		26 (57)	
Operating temp °C (°F)	15 to 35 (59 to 95)			
Outlet connection	1/8" Compression			
Certification	CE, FCC, MET (UL and CSA compliant)			

OPTIONS:

DB-RH-1800	AIR OPTION 1.8 L/min FOR RACK	DB-PH200-108	REMOTE USB
DB-RH-5000	AIR OPTION 5.0 L/min FOR RACK	DB-CASC-001	CASCADING HARDWARE KIT
DB-RH200-020	REFILL VALVE (FOR H ₂ O PRESSURE LINES)	DB-CASC-002	ON/OFF & NON-RETURN VALVE (HP)
DB-RT3U	REFILL STATION 3U FOR NM/PG PLUS RACK	DB-CASC-003	BUFFER RESERVOIR .75 LITERS (HP)
DB-RT2U	REFILL STATION 2U FOR NM/PG PLUS RACK	DB-CASC-004	PR WITH PRESSURE GAUGE
DB-10155	I/O BOARD FOR NM/PG PLUS RACK/FID	DB-CASC-005	CASCADING HARDWARE KIT (HP)
DB-10157	CABLE FOR CASCADING (I/O REQ)	DB-CASC-006	PR WITH PRESSURE GAUGE (HP)
DB-PH200-107	REMOTE RS232 (I/O REQ)	DB-RH200-022	H ₂ PIPE FITTING KIT 1/8"

CONSUMABLES:

DB-H200-031	DEIONIZER LE BAG (PACK OF 2 PCS.)
DB-N-FIL004	COALESCENT FILTER AF10 WITH CARTRIDGE
DB-10161	REPLACEMENT CARTRIDGE FOR COALESCENT FILTER AF20

ORDERING INFORMATION (for best service, please call to discuss your application before placing your order).

NM PLUS 100 RACK

DB-RNM100-EU	230-240V/50-60Hz
DB-RNM100-US	115V/60Hz
DB-RNM100-JP	100V/60Hz

NM PLUS 160 RACK

DB-RNM160-EU	230-240V/50-60Hz
DB-RNM160-US	115V/60Hz
DB-RNM160-JP	100V/60Hz

NM PLUS 250 RACK

DB-RNM250-EU	230-240V/50-60Hz
DB-RNM250-US	115V/60Hz
DB-RNM250-JP	100V/60Hz

NM PLUS 300 RACK

DB-RNM300-EU	230-240V/50-60Hz
DB-RNM300-US	115V/60Hz
DB-RNM300-JP	100V/60Hz

NM PLUS 450 RACK

DB-RNM400-EU	230-240V/50-60Hz
DB-RNM400-US	115V/60Hz
DB-RNM400-JP	100V/60Hz

NM PLUS 500 RACK

DB-RNM500-EU	230-240V/50-60Hz
DB-RNM500-US	115V/60Hz
DB-RNM500-JP	100V/60Hz

NM PLUS 600 RACK

DB-RNM600-EU	230-240V/50-60Hz
DB-RNM600-US	115V/60Hz
DB-RNM600-JP	100V/60Hz

NM PLUS 1000 RACK

DB-RNM1000-EU	230-240V/50-60Hz
DB-RNM1000-US	115V/60Hz
DB-RNM1000-JP	100V/60Hz

NM PLUS 1350 RACK

DB-RNM1350-EU	230-240V/50-60Hz
DB-RNM1350-US	115V/60Hz
DB-RNM1350-JP	100V/60Hz



PG PLUS RACK HYDROGEN GENERATOR

+ ZERO AIR OPTION

DETECTOR GRADE



FLOW RATE:
100 to 600 mL/min



PURITY:
>99.9996%



PRESSURE:
0.5 to 11 barg (7 to 160 psig)



TECHNOLOGY:
Proton Exchange Membrane (PEM) - 100% Titanium Cell



DESCRIPTION

The VICI DBS PG Plus Rack combines the reliability of the hydrogen generator with a zero air generator into a 19" rack. The generator can be installed in any suitable 19" static or mobile cabinet. This simple but effective instrument can supply all your FID gas requirements.

With a maximum output capacity of 600 mL/min, one generator can supply up to 14 FIDs. The compact design allows the generator to be installed directly in the laboratory eliminating the requirement for long gas lines and guaranteeing the delivery of high purity gas to your instrument.

Compressed air is prefiltered then purified using a state of the art combined heated catalyst module. The output zero grade air is free from total hydrocarbons to <0.1 ppm, making it ideal for all FID applications. These levels assure high sensitivity, a flat stable baseline and no ghost peaks.



APPLICATIONS

ANALYZER APPLICATIONS

- Process GC analyzers detector fuel, oxidant gas
- Emissions test analyzers fuel gas, oxidant gas
- Stack gas analyzers fuel gas, oxidant gas

OTHER LAB APPLICATIONS

- On-board gas supply for mobile laboratories

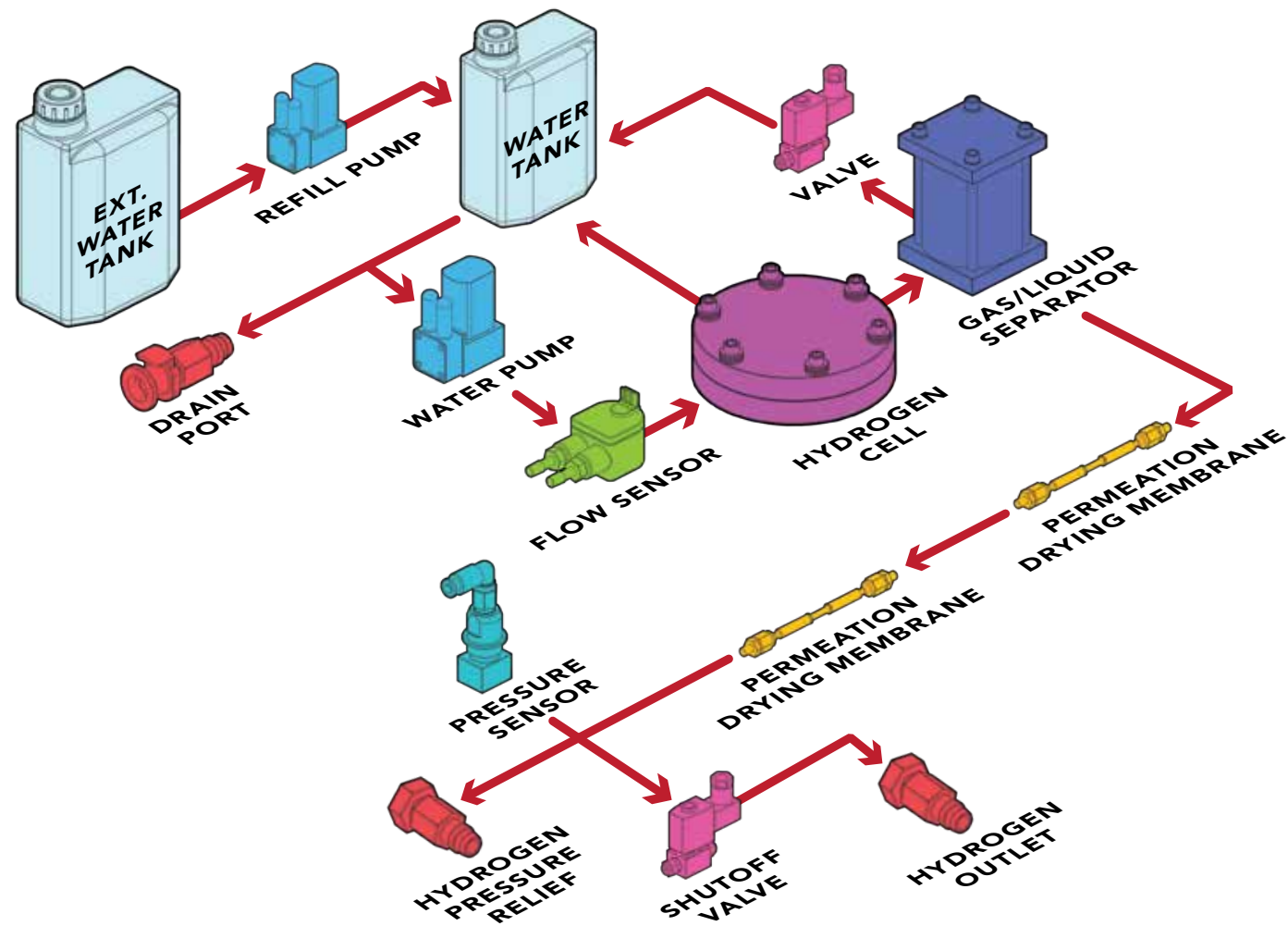

OPTIONS

- I/O board
- Remote control software (RS232 or USB)
- Cascading hardware & cables
- Refill valve and station
- H₂ pipe fitting kit
- On/Off and non-return valve (high purity)
- Buffer reservoir (high purity)
- Pressure regulator with pressure gauge
- Zero Air option

OPERATING DIAGRAM

Hydrogen is produced from the hydrolysis of deionized water across a PEM (proton exchange membrane), housed in a 100% titanium cell. The resultant hydrogen is dried via a dual stage process, a gas liquid separator and a unique dual high performance permeation membrane dryer. In addition to water all that the generator requires is a standard connection and supply of electricity for a continuous 24/7 supply of high purity hydrogen. Consumable items are limited to the replacement of a deionizer bag every 6 months.



ZERO AIR OPTION

This model has a Zero Air option.
See page 55 for information and specifications.



MODELS & SPECS	PG PLUS 100 RACK	PG PLUS 160 RACK	PG PLUS 250 RACK	PG PLUS 300 RACK	PG PLUS 500 RACK	PG PLUS 600 RACK
Flow mL/min	100	160	250	300	500	600
Purity	>99.9996%					
Dew point at 7 barg (100 psig)	-25 °C (-77 °F)					
Outlet pressure barg (psig)	0.5 to 11 (7 to 160)					
Technology	PEM (Proton Exchange Membrane) - 100% Titanium cell					
Drying system	Regenerative Permeation Membrane					
Deionized water quality	Minimum <1 micro S/cm @25°C - 1 Mohm-cm@25°C - ASTM II Recommended <0.2 microS/cm @25°C - 5 Mohm-cm @25°C - ASTM II					
External water tank liters	External 10 liter bottle and internal pump					
Safety	Automatic shut down - internal/external hydrogen leak, overpressure, and low water					
Display	Touch screen with operating parameters, system status, and safety alarms					
LED indicators	Power on/off, system ready, errors					
Interface	USB mod A					
Electrical supply	110-120V 60Hz / 220-240V 50Hz					
Power consumption watts	65	95	115	130	180	280
Dimensions mm (in)	19" rack W x 3U H x 500D (19W x 5.25H x 19.68D)					
Weight kg (lb)	17 (37.4)			19 (41.9)		
Shipping dimensions mm (in)	720W x 375H x 565D (28.3W x 14.7H x 22.2D)					
Shipping weight kg (lb)	21 (46)			23 (50)		
Operating temp °C (°F)	15 to 35 (59 to 95)					
Outlet connection	1/8" Compression					
Certification	CE, FCC, MET (UL and CSA compliant)					

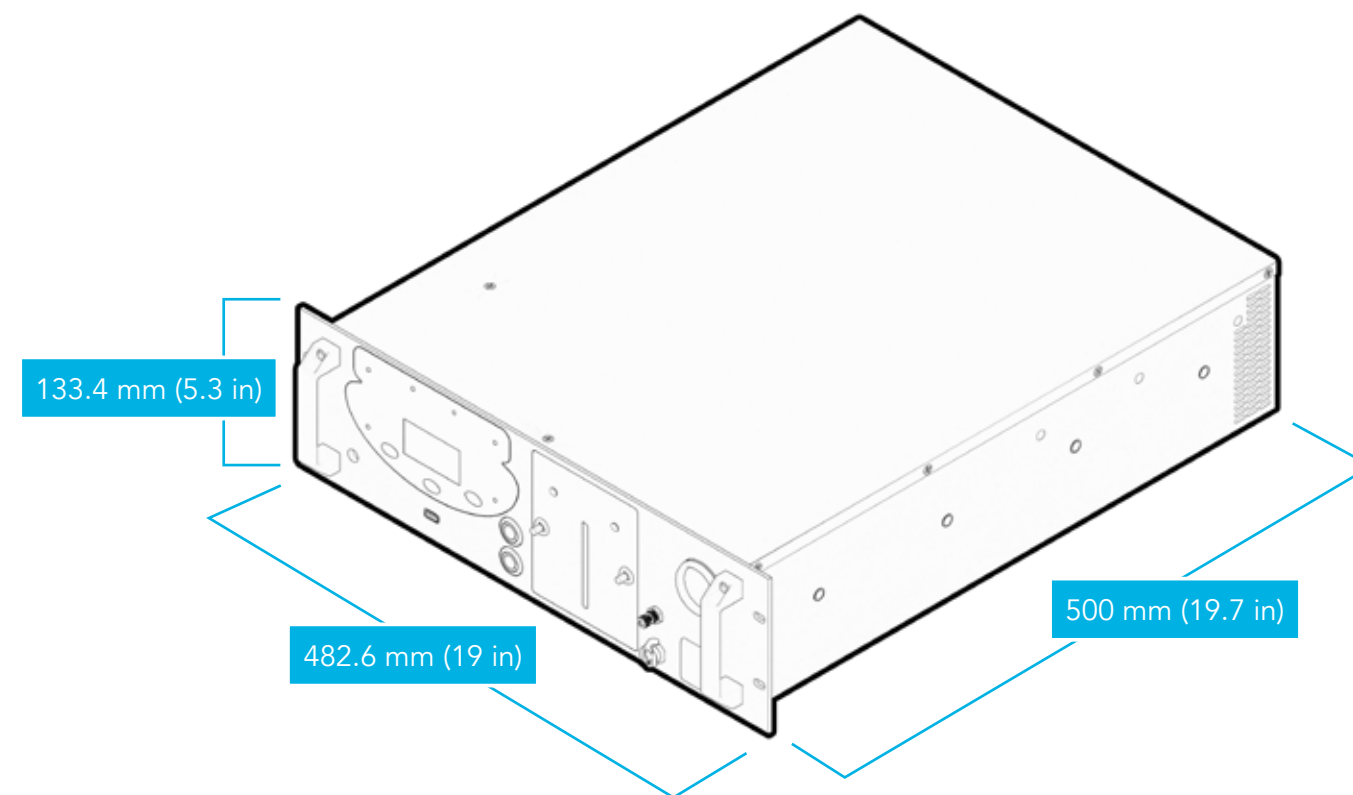

OPTIONS:

DB-RH-1800	AIR OPTION 1.8 L/min FOR RACK	DB-PH200-108	REMOTE USB
DB-RH-5000	AIR OPTION 5.0 L/min FOR RACK	DB-CASC-001	CASCADING HARDWARE KIT
DB-RH200-020	REFILL VALVE (FOR H ₂ O PRESSURE LINES)	DB-CASC-002	ON/OFF & NON-RETURN VALVE (HP)
DB-RT3U	REFILL STATION 3U FOR NM/PG PLUS RACK	DB-CASC-003	BUFFER RESERVOIR .75 LITERS (HP)
DB-RT2U	REFILL STATION 2U FOR NM/PG PLUS RACK	DB-CASC-004	PR WITH PRESSURE GAUGE
DB-10155	I/O BOARD FOR NM/PG PLUS RACK/FID	DB-CASC-005	CASCADING HARDWARE KIT (HP)
DB-10157	CABLE FOR CASCADING (I/O REQ)	DB-CASC-006	PR WITH PRESSURE GAUGE (HP)
DB-PH200-107	REMOTE RS232 (I/O REQ)	DB-RH200-022	H ₂ PIPE FITTING KIT 1/8"

CONSUMABLES:

DB-H200-031	DEIONIZER LE BAG (PACK OF 2 PCS.)
DB-N-FIL004	COALESCENT FILTER AF10 WITH CARTRIDGE
DB-10161	REPLACEMENT CARTRIDGE FOR COALESCENT FILTER AF20

ORDERING INFORMATION (for best service, please call to discuss your application before placing your order).

PG PLUS 100 RACK

DB-RHG100-EU	230-240V/50-60Hz
DB-RHG100-US	115V/60Hz
DB-RHG100-JP	100V/60Hz

PG PLUS 160 RACK

DB-RHG160-EU	230-240V/50-60Hz
DB-RHG160-US	115V/60Hz
DB-RHG160-JP	100V/60Hz

PG PLUS 250 RACK

DB-RHG250-EU	230-240V/50-60Hz
DB-RHG250-US	115V/60Hz
DB-RHG250-JP	100V/60Hz

PG PLUS 300 RACK

DB-RHG300-EU	230-240V/50-60Hz
DB-RHG300-US	115V/60Hz
DB-RHG300-JP	100V/60Hz

PG PLUS 500 RACK

DB-RHG500-EU	230-240V/50-60Hz
DB-RHG500-US	115V/60Hz
DB-RHG500-JP	100V/60Hz

PG PLUS 600 RACK

DB-RHG600-EU	230-240V/50-60Hz
DB-RHG600-US	115V/60Hz
DB-RHG600-JP	100V/60Hz



NM PLUS FID STATION H₂ + ZERO AIR GENERATOR

CARRIER GRADE



FLOW RATE:
100 to 1350 mL/min



PURITY:
>99.99996%



PRESSURE:
1.4 to 11 barg (20 to 160 psig)



TECHNOLOGY:
Proton Exchange Membrane (PEM) - 100% Titanium Cell



DESCRIPTION

The VICI DBS NM Plus FID Station is a unique instrument that combines the reliability of the hydrogen generator with a zero air generator into one compact package.

The FID Station can be installed under the GC taking no additional bench space. This simple but effective instrument can supply all your carrier gas and FID gas requirements.

With a maximum output capacity of 1350 mL/min, one generator can supply up to 32 GCs. The compact design allows the generator to be installed directly in the laboratory eliminating the requirement for long gas lines and guaranteeing the delivery of high purity gas to your GC.



NM PLUS APPLICATIONS

GC APPLICATIONS

- GC carrier gas
- GC/MS carrier gas
- GC fuel gas
- GC-ELCD & Hall ELCD reaction gas

SPECTROSCOPY APPLICATIONS

- ICP-MS Collision cell reaction gas

ANALYZER APPLICATIONS

- Total Hydrocarbon Analyzer (THA) fuel gas
- Chemisorption/Physisorption measurement gas

OTHER APPLICATIONS

- Chemical vapor deposition instrumentation (CVD)
- Plasma cleaning instrumentation (UCP)
- High efficiency process gas
- Hydrogenation reactors
- Hydrogen fuel cells
- Weather balloon filling
- Electronic nose (eNose)
- 3-D chromatography

CHOOSE YOUR ZERO AIR FLOW RATE

Zero Air is built into the NM Plus FID Station and you have two choices for flow rates. When ordering, be sure to select the Zero Air flow rate best suited to your needs.

ZERO AIR FLOW OPTIONS

	DB-FH-1800	DB-FH-5000
Flow mL/min	1800	5000
Purity - hydrocarbons + CO	<0.1 ppm	
Inlet pressure barg (psig)	4.5 to 10 (65 to 145)	
Inlet air quality	Clean dry compressed air ISO8573-1:2010 Class 1.2.1	
Max outlet pressure barg (psig)	5 (73)	
Max HC in	100 ppm	
Max CO in	50 ppm	

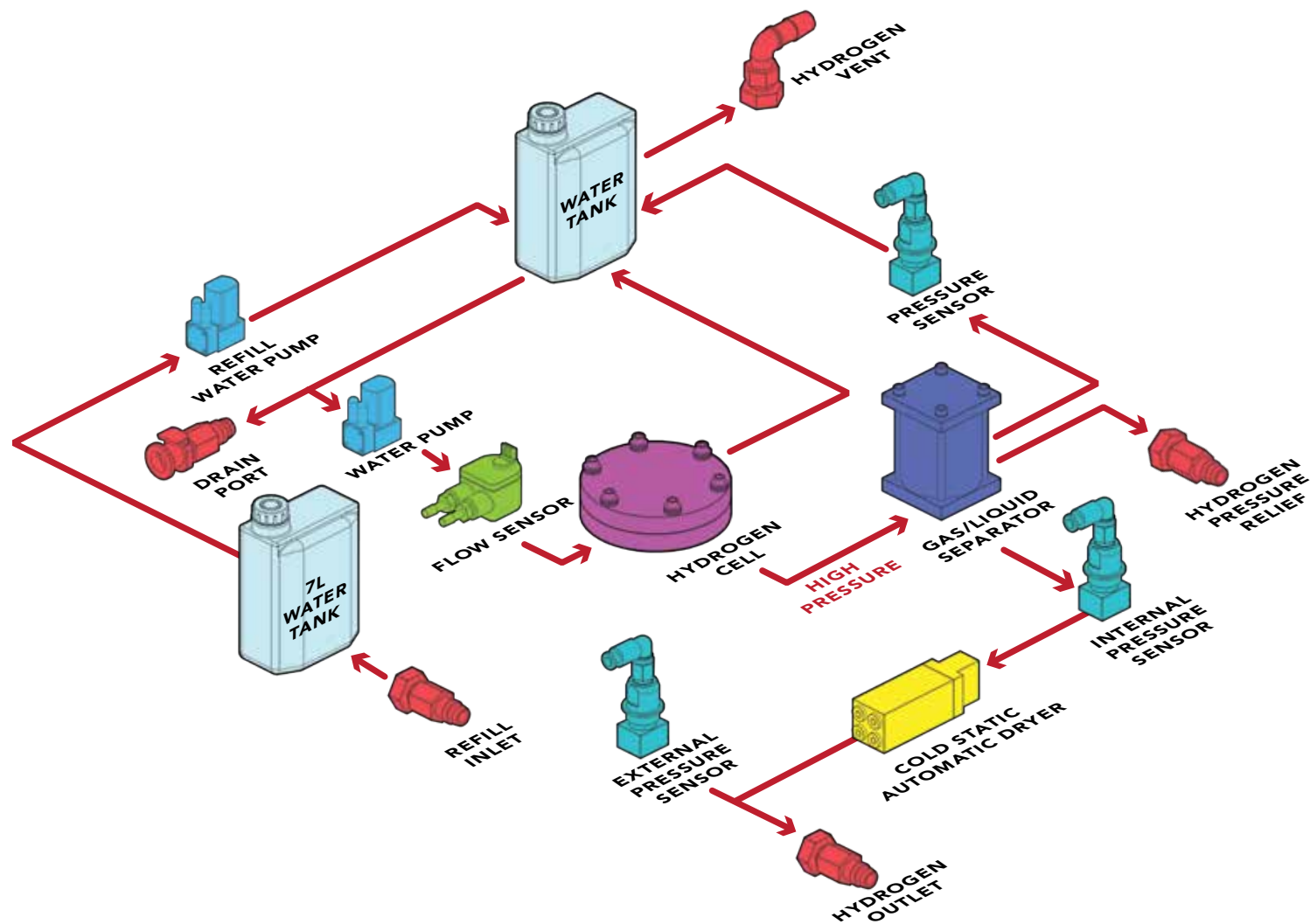

OPERATING DIAGRAM

Hydrogen is produced from the hydrolysis of deionized water across a PEM (proton exchange membrane), housed in a 100% titanium cell. The output hydrogen is dried via a dual stage process, a gas liquid separator and a unique dual high performance permeation dryer. In addition to water all the generator requires is a standard connection and supply of electricity for a continuous 24/7 supply of high purity hydrogen. Consumable items are limited to the replacement of a deionizer bag every six months.



OPTIONS

- I/O board
- Remote control software (RS232 or USB)
- Cascading hardware & cables
- FID Station MS Extension
- On/Off and non-return valve (high purity)
- Buffer reservoir (high purity)
- Pressure regulator with pressure gauge
- Zero Air flow rate



MODELS & SPECS

	NM PLUS 100 FID STATION	NM PLUS 300 FID STATION	NM PLUS 600 FID STATION	NM PLUS 1000 FID STATION	NM PLUS 1350 FID STATION
Flow mL/min	100	300	600	1000	1350
Purity	>99.99996%				
Dew point at 7 barg (100 psig)	-73 °C (-103°F)				
Outlet pressure barg (psig)	1.4 to 11 (20 to 160)				
Technology	PEM (proton exchange membrane) - 100% titanium cell				
Drying system	No maintenance cold dual dynamic regeneration system				
Deionized water quality	Minimum <1 micro S/cm @ 25°C - 1 Mohm-cm @ 25°C - ASTM II Recommended <0.2 microS/cm @ 25°C - 5 Mohm-cm @ 25°C - ASTM II				
Internal water tank liters	7				
Safety	Automatic shut down - internal/external hydrogen leak, overpressure, and low water				
Display	Touch screen with operating parameters, system status, and safety alarms				
LED Indicators	Power on/off, system ready, errors				
Interface	USB mod A				
Electrical supply	110-120V 60Hz / 220-240V 50 Hz				
Power consumption watts	90	150	300	400	450
Dimensions mm (in)	690W x 150H x 680D (27W x 6H x 26.7D)				
Weight kg (lb)	41 (90)	42 (92.5)	43 (95)	44 (97)	45 (99)
Shipping dimensions mm (in)	890W x 385H x 800D (35W x 15.1H x 31.4D)				
Shipping weight kg (lb)	47 (103)	48 (106)	49 (108)	50 (110)	51 (112)
Operating temp °C (°F)	15 to 35 (59 to 95)				
Outlet connection	1/8" Compression				
Certification	CE, FCC, MET (UL and CSA compliant)				

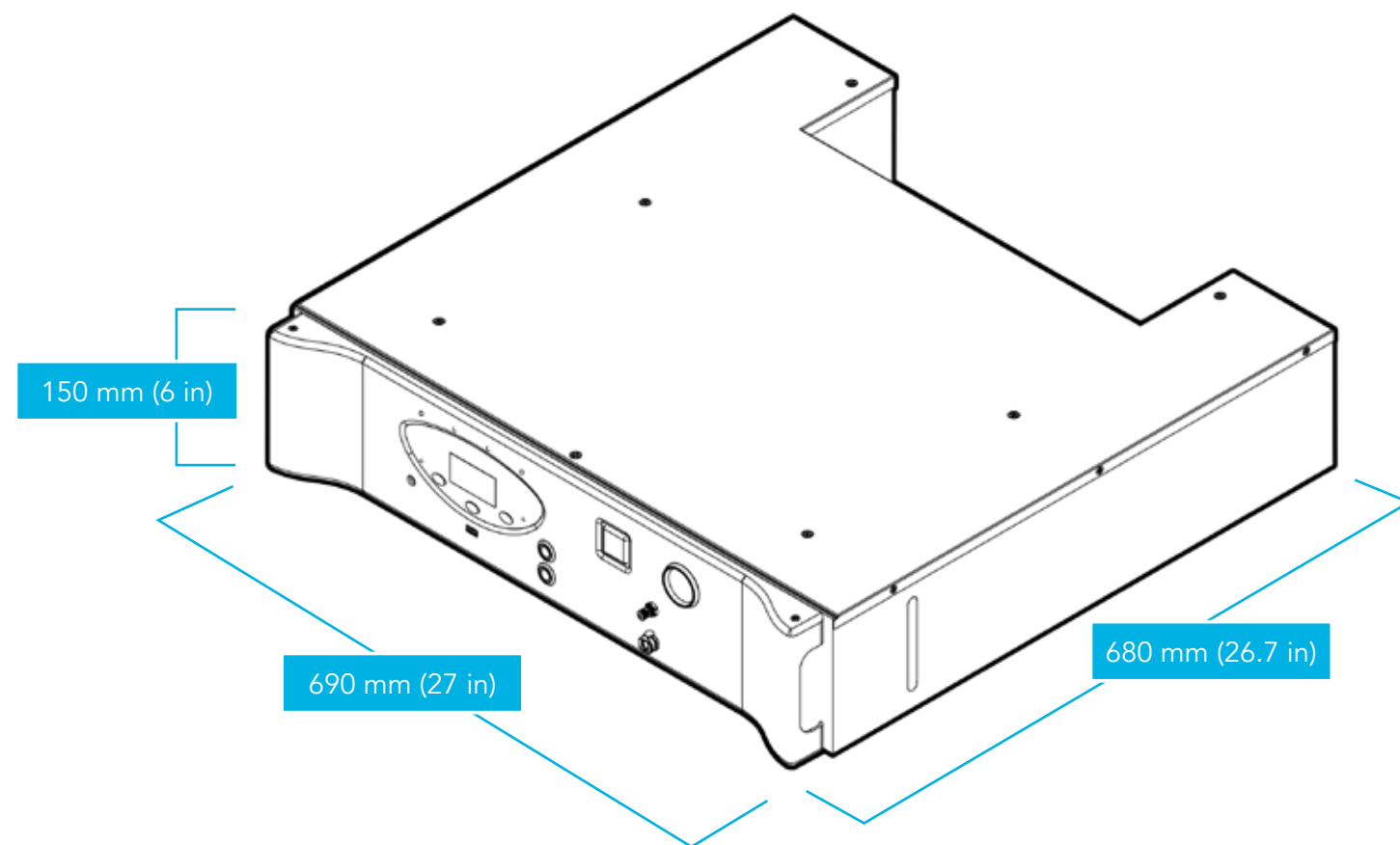

OPTIONS:

DB-FH-MS	FID STATION MS EXTENSION	DB-CASC-002	ON/OFF & NON-RETURN VALVE (HP)
DB-10155	I/O BOARD FOR RACK/FID NM & PG PLUS	DB-CASC-003	BUFFER RESERVOIR .75 LITERS (HP)
DB-10157	CABLE FOR CASCADING (I/O REQ)	DB-CASC-004	PR WITH PRESSURE GAUGE
DB-PH200-107	REMOTE RS232 (I/O REQ)	DB-CASC-005	CASCADING HARDWARE KIT (HP)
DB-PH200-108	REMOTE USB	DB-CASC-006	PR WITH PRESSURE GAUGE (HP)
DB-CASC-001	CASCADING HARDWARE KIT		

CONSUMABLES:

DB-H200-031	DEIONIZER LE BAG (PACK OF 2 PCS.)
DB-N-FIL004	COALESCENT FILTER AF20 WITH CARTRIDGE
DB-10161	REPLACEMENT CARTRIDGE FOR COALESCENT FILTER AF10

ORDERING INFORMATION (for best service, please call to discuss your application before placing your order).

NM PLUS 100 FID STATION

DB-FNM100-EU	230-240V/50-60Hz
DB-FNM100-US	115V/60Hz
DB-FNM100-JP	100V/60Hz

NM PLUS 300 FID STATION

DB-FNM300-EU	230-240V/50-60Hz
DB-FNM300-US	115V/60Hz
DB-FNM300-JP	100V/60Hz

NM PLUS 600 FID STATION

DB-FNM600-EU	230-240V/50-60Hz
DB-FNM600-US	115V/60Hz
DB-FNM600-JP	100V/60Hz

NM PLUS 1000 FID STATION

DB-FNM1000-EU	230-240V/50-60Hz
DB-FNM1000-US	115V/60Hz
DB-FNM1000-JP	100V/60Hz

NM PLUS 1350 FID STATION

DB-FNM1350-EU	230-240V/50-60Hz
DB-FNM1350-US	115V/60Hz
DB-FNM1350-JP	100V/60Hz



PG PLUS FID STATION H₂ + ZERO AIR GENERATOR

DETECTOR GRADE



FLOW RATE:
100 to 250 mL/min



PURITY:
>99.9996%



PRESSURE:
0.5 to 11 barg (7 to 160 psig)



TECHNOLOGY:
Proton Exchange Membrane (PEM) - 100% Titanium Cell



DESCRIPTION

The VICI DBS PG Plus FID Station is a unique instrument that combines the reliability of the hydrogen generator with a zero air generator into one compact package.

The FID Station can be installed under the GC taking no additional bench space. This simple but effective instrument can supply all your carrier gas and FID gas requirements.

With a maximum output capacity of 250 mL/min, one generator can supply up to 6 GC detectors. The compact design allows the generator to be installed directly in the laboratory eliminating the requirement for long gas lines and guaranteeing the delivery of high purity gas to your GC.



APPLICATIONS

GC APPLICATIONS

- GC-FID fuel gas
- GC-NPD plasma gas
- GC-FPD fuel gas

ANALYZER APPLICATIONS

- Total Hydrocarbon Analyzer (THA) fuel gas

OTHER APPLICATIONS

- Hydrogenation reactors
- Hydrogen fuel cells

CHOOSE YOUR ZERO AIR FLOW RATE

Zero Air is built into the PG Plus FID Station and you have two choices for flow rates. When ordering, be sure to select the Zero Air flow rate best suited to your needs.

ZERO AIR FLOW OPTIONS

	DB-FH-1800	DB-FH-5000
Flow mL/min	1800	5000
Purity - hydrocarbons + CO	<0.1 ppm	
Inlet pressure barg (psig)	4.5 to 10 (65 to 145)	
Inlet air quality	Clean dry compressed air ISO8573-1:2010 Class 1.2.1	
Max outlet pressure barg (psig)	5 (73)	
Max HC in	100 ppm	
Max CO in	50 ppm	

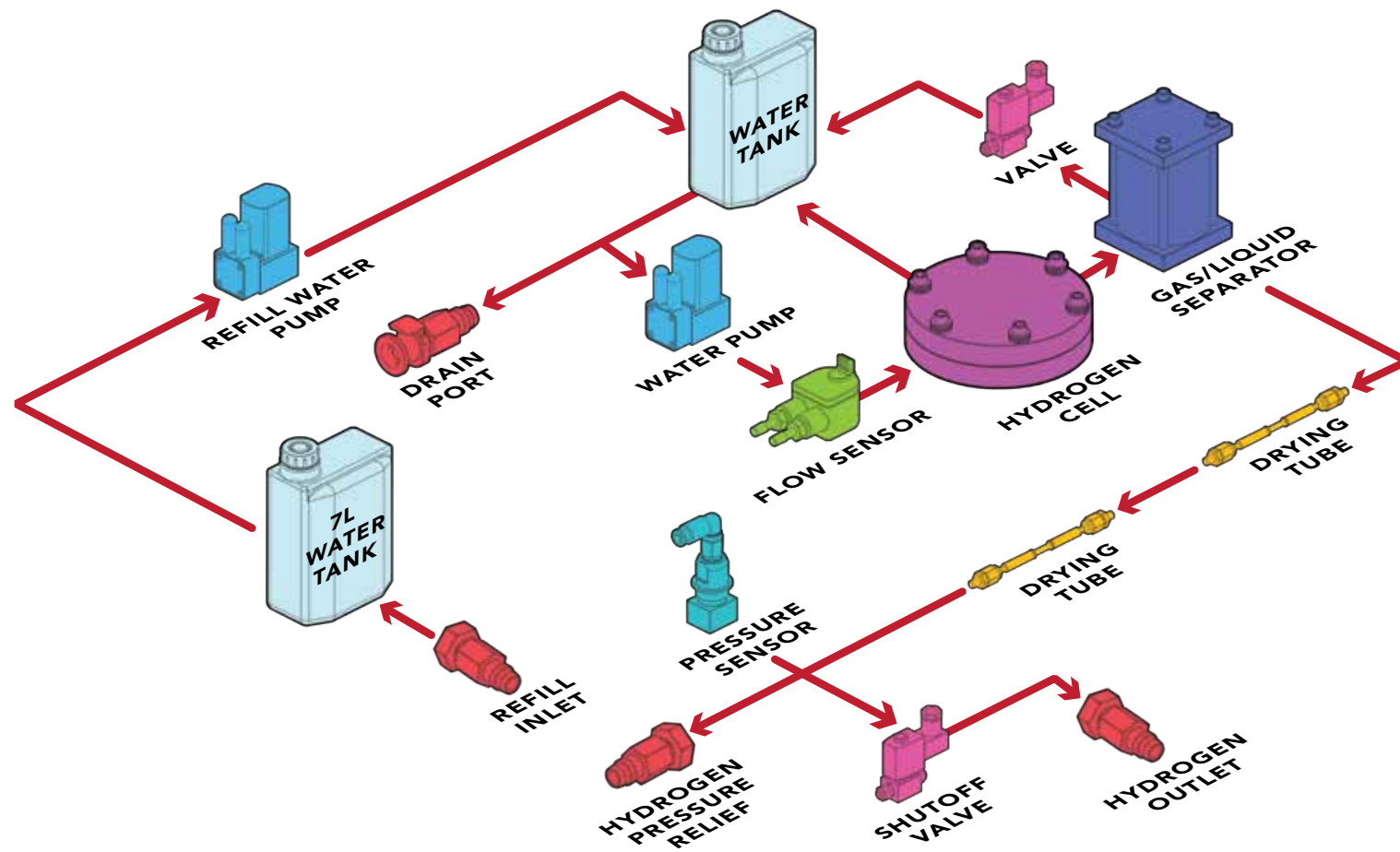

OPERATING DIAGRAM

Hydrogen is produced from the hydrolysis of deionized water across a PEM (proton exchange membrane), housed in a 100% titanium cell. The output hydrogen is dried via a dual stage process, a gas liquid separator and a unique dual high performance membrane dryer. In addition to water all that the generator requires is a standard connection and supply of electricity for a continuous 24/7 supply of high purity hydrogen. Consumable items are limited to the replacement of a deionizer bag every six months.



OPTIONS

- I/O board
- Remote control software (RS232 or USB)
- Cascading hardware & cables
- FID Station MS Extension
- On/Off and non-return valve (high purity)
- Buffer reservoir (high purity)
- Pressure regulator with pressure gauge
- Zero Air flow rate



MODELS & SPECS	PG PLUS 100 FID STATION	PG PLUS 250 FID STATION
Flow mL/min	100	250
Purity	>99.9996%	
Dew point at 7 barg (100 psig)	-25 °C (-77°F)	
Outlet pressure barg (psig)	0.5 to 11 (7 to 160)	
Technology	PEM (proton exchange membrane) - 100% titanium cell	
Drying system	Regenerative permeation membrane	
Deionised water quality	Minimum <1 micro S/cm @ 25°C - 1 Mohm-cm @ 25°C - ASTM II Recommended <0.2 microS/cm @ 25°C - 5 Mohm-cm @ 25°C - ASTM II	
Internal water tank liters	7	
Safety	Automatic shut down - internal/external hydrogen leak, overpressure and low water	
Display	Touch screen with operating parameters, system status and safety alarms	
LED Indicators	Power on/off, system ready, errors	
Interface	USB mod A	
Load capacity kg (lb)	80 (176)	
Electrical supply	110-120V 60Hz / 220-240V 50Hz	
Power consumption watts	65	115
Dimensions mm (in)	690W x 150H x 680D (27W x 6H x 26.7D)	
Weight kg (lb)	39 (86)	
Shipping dimensions mm (in)	890W x 385H x 800D (35W x 15.1H x 31.4D)	
Shipping weight kg (lb)	45 (99)	
Operating temp °C (°F)	15 to 35 (59 to 95)	
Outlet connection	1/8" Compression	
Certification	CE, FCC, MET (UL and CSA compliant)	

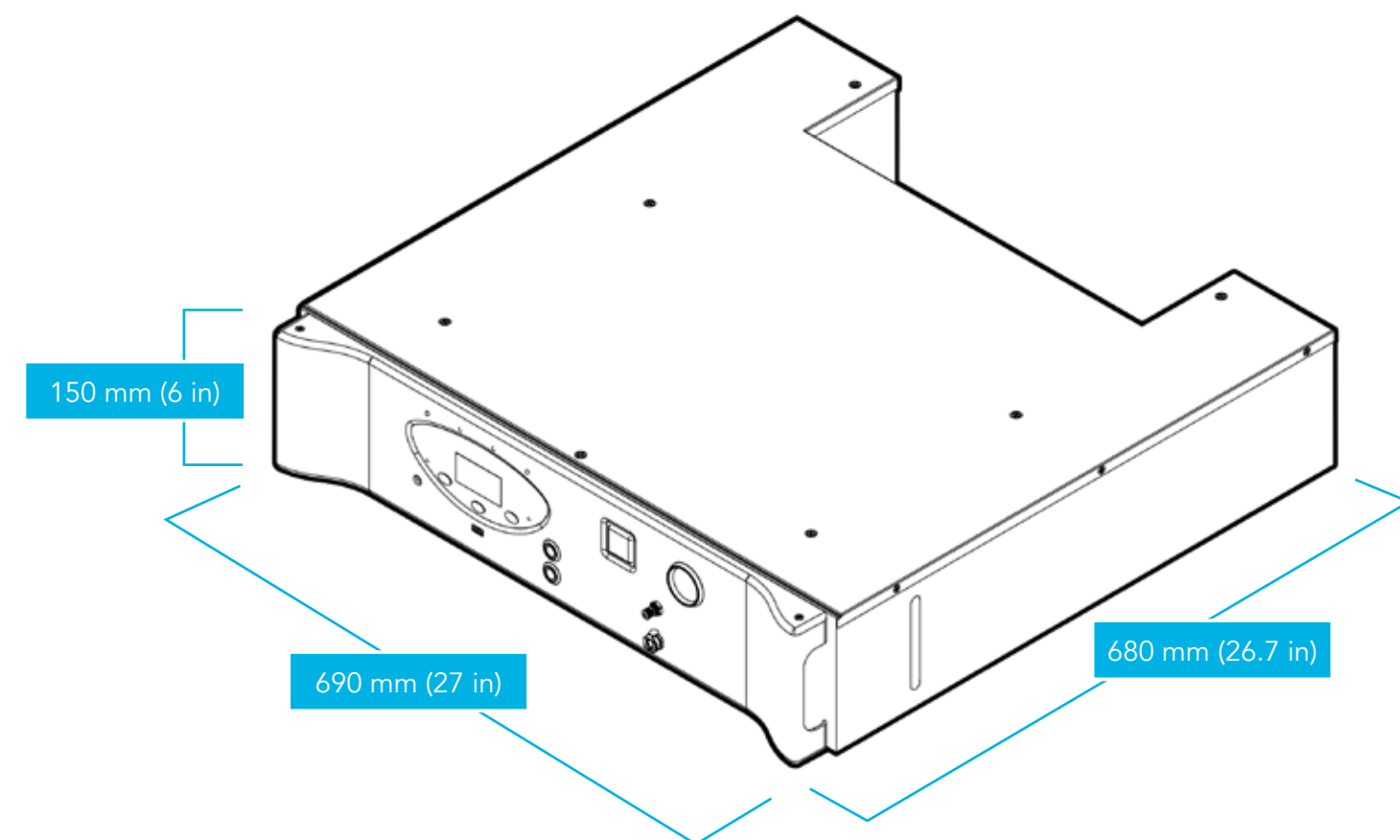

OPTIONS:

DB-FH-MS	FID STATION MS EXTENSION	DB-CASC-002	ON/OFF & NON-RETURN VALVE (HP)
DB-10155	I/O BOARD FOR RACK/FID NM & PG PLUS	DB-CASC-003	BUFFER RESERVOIR .75 LITERS (HP)
DB-10157	CABLE FOR CASCADING (I/O REQ)	DB-CASC-004	PR WITH PRESSURE GAUGE
DB-PH200-107	REMOTE RS232 (I/O REQ)	DB-CASC-005	CASCADING HARDWARE KIT (HP)
DB-PH200-108	REMOTE USB	DB-CASC-006	PR WITH PRESSURE GAUGE (HP)
DB-CASC-001	CASCADING HARDWARE KIT		

CONSUMABLES:

DB-H200-031	DEIONIZER LE BAG (PACK OF 2 PCS.)
DB-N-FIL004	COALESCENT FILTER AF20 WITH CARTRIDGE
DB-10161	REPLACEMENT CARTRIDGE FOR COALESCENT FILTER AF10

ORDERING INFORMATION (for best service, please call to discuss your application before placing your order).

PG PLUS 100 FID STATION

DB-FHG100-EU	230-240V/50-60Hz
DB-FHG100-US	115V/60Hz
DB-FHG100-JP	100V/60Hz

PG PLUS 250 FID STATION

DB-FHG250-EU	230-240V/50-60Hz
DB-FHG250-US	115V/60Hz
DB-FHG250-JP	100V/60Hz



NM & PG FID TOWER H₂ + ZERO AIR GENERATORS



FLOW RATE:
100 to 1350 mL/min



PURITY:
>99.99996%



PRESSURE:
0.5 to 11 barg (7 to 160 psig)



TECHNOLOGY:
Proton Exchange Membrane (PEM) - 100% Titanium Cell



DESCRIPTION

The VICI DBS NM Plus and PG Plus FID Towers are unique instruments that combine the reliability of the hydrogen generator with a zero air generator into one compact package. The compact design allows the generator to be installed directly in the laboratory next to the GC, eliminating the requirement for long gas lines, assuring the delivery of high purity gas to your instruments, and preserving valuable bench space.

With a maximum output capacity of 1350 mL/min, one generator can supply up to 33 GCs. Compressed air is prefiltered and then purified using a state of the art combined heated catalyst module. A sophisticated control system connected to an easy to use touch screen continuously monitors vital operating parameters to ensure safe and consistent performance. Built-in sensors will shut the generator down if internal/external leaks are present, contaminated water, low water or overpressure.

CHOOSE YOUR ZERO AIR FLOW RATE

Zero Air is built into the PG Plus FID Tower and you have two choices for flow rates. When ordering, be sure to select the Zero Air flow rate best suited to your needs.

ZERO AIR FLOW OPTIONS	DB-FH-1800	DB-FH-5000
Flow mL/min	1800	5000
Purity - hydrocarbons + CO	<0.1 ppm	
Inlet pressure barg (psig)	4.5 to 10 (65 to 145)	
Inlet air quality	Clean dry compressed air ISO8573-1:2010 Class 1.2.1	
Max outlet pressure barg (psig)	5 (73)	
Max HC in	100 ppm	
Max CO in	50 ppm	



NM PLUS APPLICATIONS

GC APPLICATIONS

- GC carrier gas
- GC/MS carrier gas
- GC fuel gas
- GC-ELCD & HALL reaction gas

SPECTROSCOPY APPLICATIONS

- ICP-MS Collision cell reaction gas

ANALYZER APPLICATIONS

- Total Hydrocarbon Analyzer (THA) fuel gas
- Chemisorption/Physisorption measurement gas

OTHER APPLICATIONS

- Chemical vapor deposition instrumentation (CVD)
- Plasma cleaning instrumentation (UCP)
- High efficiency process gas
- Hydrogenation reactors
- Hydrogen fuel cells
- Weather balloon filling
- Electronic nose (eNose)
- 3-D chromatography

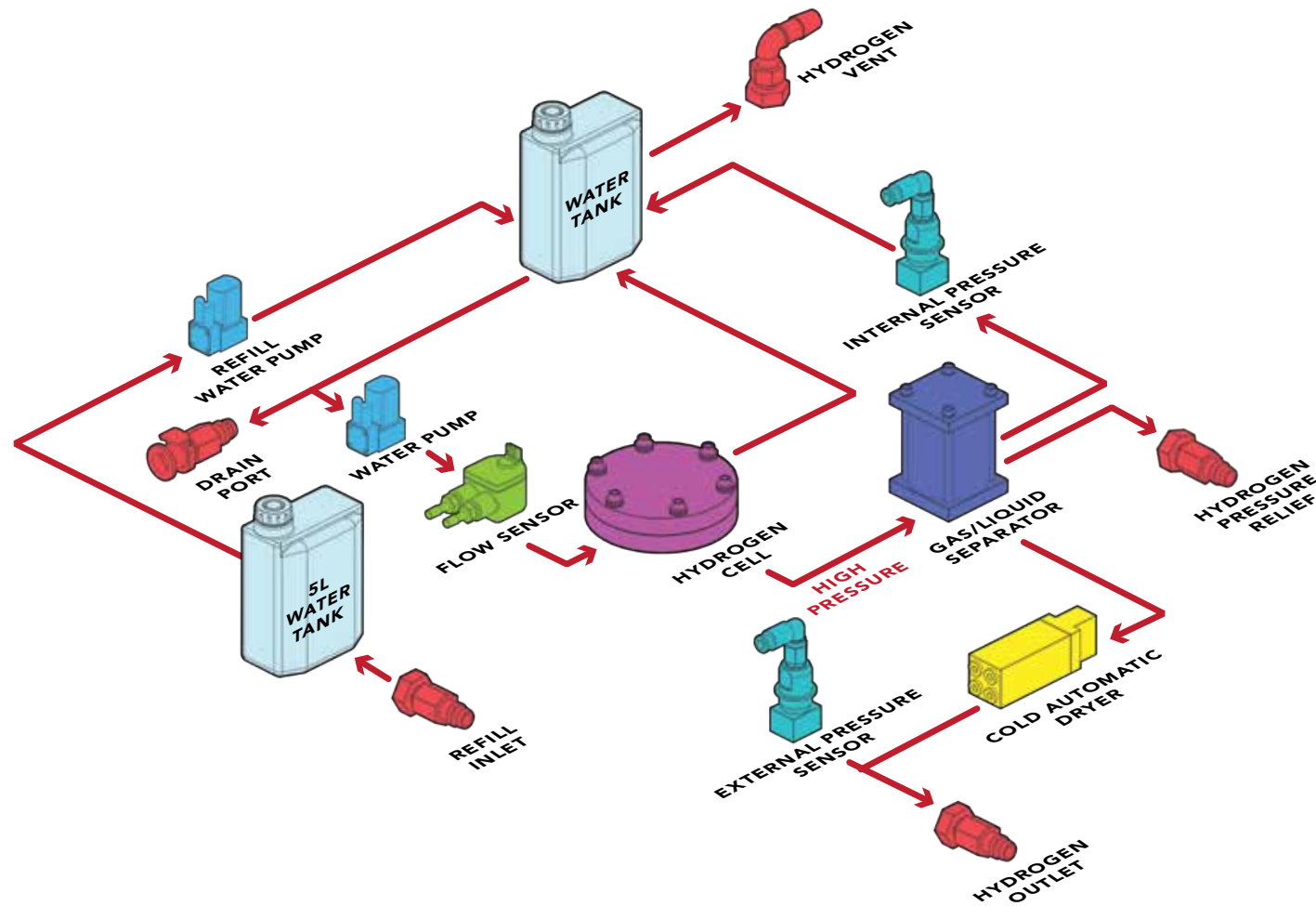

OPERATING DIAGRAM

Hydrogen is produced from the hydrolysis of deionized water across a PEM (proton exchange membrane), housed in a 100% titanium cell. The output hydrogen is dried via a dual stage process, a gas liquid separator and a unique dual high performance permeation dryer. In addition to water all the generator requires is a standard connection and supply of electricity for a continuous 24/7 supply of high purity hydrogen. Consumable items are limited to the replacement of a deionizer bag every six months.

CARRIER GRADE

NM MODELS & SPECS

	NM PLUS 100 FID TOWER	NM PLUS 160 FID TOWER	NM PLUS 250 FID TOWER	NM PLUS 300 FID TOWER
Flow mL/min	100	160	250	300
Purity	>99.99996%			
Dew point at 7 barg (100 psig)	-73 °C (-103°F)			
Outlet pressure barg (psig)	1.4 to 11 (20 to 160)			
Technology	PEM (Proton Exchange Membrane) - 100% titanium cell			
Drying system	No maintenance cold dual dynamic regeneration system			
Deionized water quality	Minimum <1 micro S/cm @25°C - 1 Mohm-cm@25°C - ASTM II Recommended <0.2 microS/cm @25°C - 5 Mohm-cm @25°C - ASTM II			
Internal water tank liters	5			
Safety	Automatic shut down - internal/external hydrogen leak, overpressure, and low water			
Display	Touch screen with operating parameters, system status, and safety alarms			
LED Indicators	Power on/off, system ready, errors			
Interface	USB mod A			
Electrical supply	110-120V 60Hz / 220-240V 50 Hz			
Power consumption watts	90	115	140	150
Dimensions mm (in)	140W x 490H x 580D (5.5W x 19H x 22.8D)			
Weight kg (lb)	23 (50)		24 (53)	
Shipping dimensions mm (in)	770W x 590H x 410D (30.3W x 23.2H x 16.1D)			
Shipping weight kg (lb)	27 (59.5)		28 (62)	
Operating temp °C (°F)	15 to 35 (59 to 95)			
Outlet connection	1/8" Compression			
Certification	CE, FCC, MET (UL and CSA compliant)			

ORDERING INFORMATION (for best service, please call to discuss your application before placing your order).

NM PLUS 100 FID TOWER

- DB-FTNM100-EU 230-240V/50-60Hz
- DB-FTNM100-US 115V/60Hz
- DB-FTNM100-JP 100V/60Hz

NM PLUS 160 FID TOWER

- DB-FTNM160-EU 230-240V/50-60Hz
- DB-FTNM160-US 115V/60Hz
- DB-FTNM160-JP 100V/60Hz

NM PLUS 250 FID TOWER

- DB-FTNM250-EU 230-240V/50-60Hz
- DB-FTNM250-US 115V/60Hz
- DB-FTNM250-JP 100V/60Hz

NM PLUS 300 FID TOWER

- DB-FTNM300-EU 230-240V/50-60Hz
- DB-FTNM300-US 115V/60Hz
- DB-FTNM300-JP 100V/60Hz

NM MODELS & SPECS

	NM PLUS 500 FID TOWER	NM PLUS 600 FID TOWER	NM PLUS 1000 FID TOWER	NM PLUS 1350 FID TOWER
Flow mL/min	500	600	1000	1350
Purity	>99.99996%			
Dew point at 7 barg (100 psig)	-73 °C (-103°F)			
Outlet pressure barg (psig)	1.4 to 11 (20 to 160)			
Technology	PEM (Proton Exchange Membrane) - 100% titanium cell			
Drying system	No maintenance cold dual dynamic regeneration system			
Deionized water quality	Minimum < 1 micro S/cm @25oC - 1 Mohm-cm@25oC - ASTM II Recommended < 0.2 microS/cm @25oC - 5 Mohm-cm @25oC - ASTM II			
Internal water tank liters	5			
Safety	Automatic shut down - internal/external hydrogen leak, overpressure, and low water			
Display	Touch screen with operating parameters, system status, and safety alarms			
LED Indicators	Power on/off, system ready, errors			
Interface	USB mod A			
Electrical supply	110-120V 60Hz / 220-240V 50 Hz			
Power consumption watts	200	300	400	500
Dimensions mm (in)	140W x 490H x 580D (5.5W x 19H x 22.8D)			
Weight kg (lb)	25 (55)		26 (57)	
Shipping dimensions mm (in)	770W x 590H x 410D (30.3W x 23.2H x 16.1D)			
Shipping weight kg (lb)	29 (64)		30 (66)	
Operating temp °C (°F)	15 to 35 (59 to 95)			
Outlet connection	1/8" Compression			
Certification	CE, FCC, MET (UL and CSA compliant)			



OPTIONS

- I/O board
- Remote control software (RS232 or USB)
- Cascading hardware & cables
- Pressure regulator with pressure gauge
- On/Off and non-return valve
- Buffer reservoir
- Zero Air flow rate



ORDERING INFORMATION (for best service, please call to discuss your application before placing your order).

NM PLUS 500 FID TOWER

DB-FTNM500-EU 230-240V/50-60Hz
DB-FTNM500-US 115V/60Hz
DB-FTNM500-JP 100V/60Hz

NM PLUS 600 FID TOWER

DB-FTNM600-EU 230-240V/50-60Hz
DB-FTNM600-US 115V/60Hz
DB-FTNM600-JP 100V/60Hz

NM PLUS 1000 FID TOWER

DB-FTNM1000-EU 230-240V/50-60Hz
DB-FTNM1000-US 115V/60Hz
DB-FTNM1000-JP 100V/60Hz

NM PLUS 1350 FID TOWER

DB-FTNM1350-EU 230-240V/50-60Hz
DB-FTNM1350-US 115V/60Hz
DB-FTNM1350-JP 100V/60Hz



PG PLUS APPLICATIONS

GC APPLICATIONS

- GC-FID fuel gas
- GC-NPD plasma gas
- GC-FPD fuel gas

ANALYZER APPLICATIONS

- Total Hydrocarbon Analyzer (THA) fuel gas

OTHER APPLICATIONS

- Hydrogenation reactors
- Hydrogen fuel cells

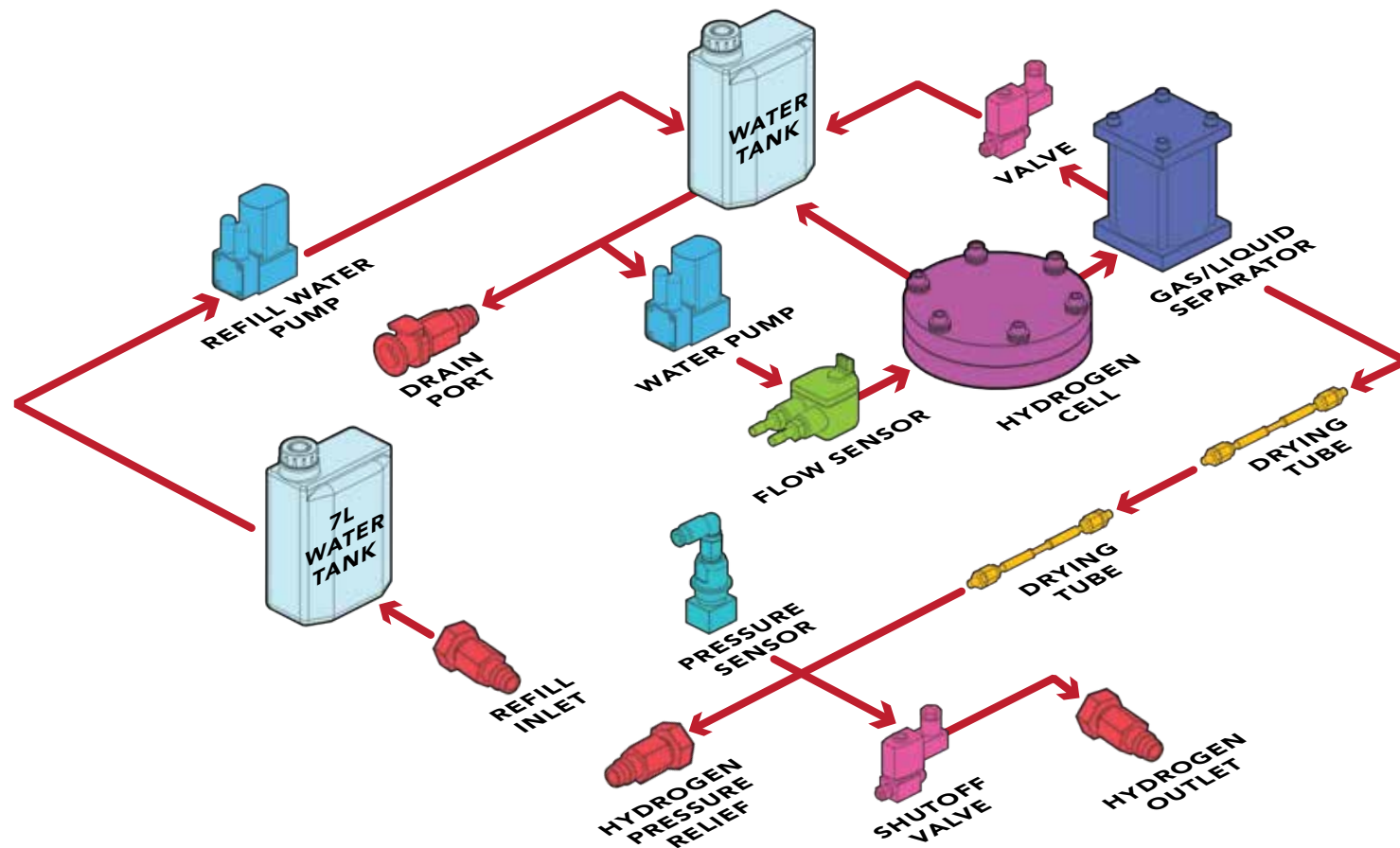

OPERATING DIAGRAM

Hydrogen is produced from the hydrolysis of deionized water across a PEM (proton exchange membrane), housed in a 100% titanium cell. The output hydrogen is dried via a dual stage process, a gas liquid separator and a unique dual high performance permeation dryer. In addition to water all the generator requires is a standard connection and supply of electricity for a continuous 24/7 supply of high purity hydrogen. Consumable items are limited to the replacement of a deionizer bag every six months.

DETECTOR GRADE

PG MODELS & SPECS

	PG PLUS 100 FID TOWER	PG PLUS 160 FID TOWER	PG PLUS 250 FID TOWER	PG PLUS 300 FID TOWER	PG PLUS 500 FID TOWER	PG PLUS 600 FID TOWER
H ₂ Flow mL/min	100	160	250	300	500	600
Purity	>99.9996%					
Dew point at 7 barg (100 psig)	-25 °C (-77 °F)					
Outlet pressure barg (psig)	0.5 to 11 (7 to 160)					
Technology	PEM (Proton Exchange Membrane) - 100% Titanium cell					
Drying system	Regenerative Permeation Membrane					
Deionized water quality	Minimum < 1 micro S/cm @25°C - 1 Mohm-cm@25°C - ASTM II Recommended < 0.2 microS/cm @25°C - 5 Mohm-cm @25°C - ASTM II					
Internal water tank liters	5					
Safety	Automatic shut down - internal/external hydrogen leak, overpressure, and low water					
Display	Touch screen with operating parameters, system status, and safety alarms					
LED indicators	Power on/off, system ready, errors					
Interface	USB mod A					
Electrical supply	110-120V 60Hz / 220-240V 50Hz					
Power consumption watts	65	85	115	133	180	280
Dimensions mm (in)	140W x 490H x 580D (5.5W x 19H x 22.8D)					
Weight kg (lb)	22 (48.5)		23 (50)		24 (53)	
Shipping dimensions mm (in)	770W x 590H x 410D (30.3W x 23.2H x 16.1D)					
Shipping weight kg (lb)	26 (57)		27 (59.5)		28 (62)	
Operating temp °C (°F)	15 to 35 (59 to 95)					
Outlet connection	1/8" Compression					
Certification	CE, FCC, MET (UL and CSA compliant)					

ORDERING INFORMATION (for best service, please call to discuss your application before placing your order).

PG PLUS 100 FID TOWER

DB-FTHG100-EU 230-240V/50-60Hz
DB-FTHG100-US 115V/60Hz
DB-FTHG100-JP 100V/60Hz

PG PLUS 160 FID TOWER

DB-FTHG160-EU 230-240V/50-60Hz
DB-FTHG160-US 115V/60Hz
DB-FTHG160-JP 100V/60Hz

PG PLUS 250 FID TOWER

DB-FTHG250-EU 230-240V/50-60Hz
DB-FTHG250-US 115V/60Hz
DB-FTHG250-JP 100V/60Hz

PG PLUS 300 FID TOWER

DB-FTHG300-EU 230-240V/50-60Hz
DB-FTHG300-US 115V/60Hz
DB-FTHG300-JP 100V/60Hz

PG PLUS 500 FID TOWER

DB-FTHG500-EU 230-240V/50-60Hz
DB-FTHG500-US 115V/60Hz
DB-FTHG500-JP 100V/60Hz

PG PLUS 600 FID TOWER

DB-FTHG600-EU 230-240V/50-60Hz
DB-FTHG600-US 115V/60Hz
DB-FTHG600-JP 100V/60Hz



ZERO AIR OPTION MODULES

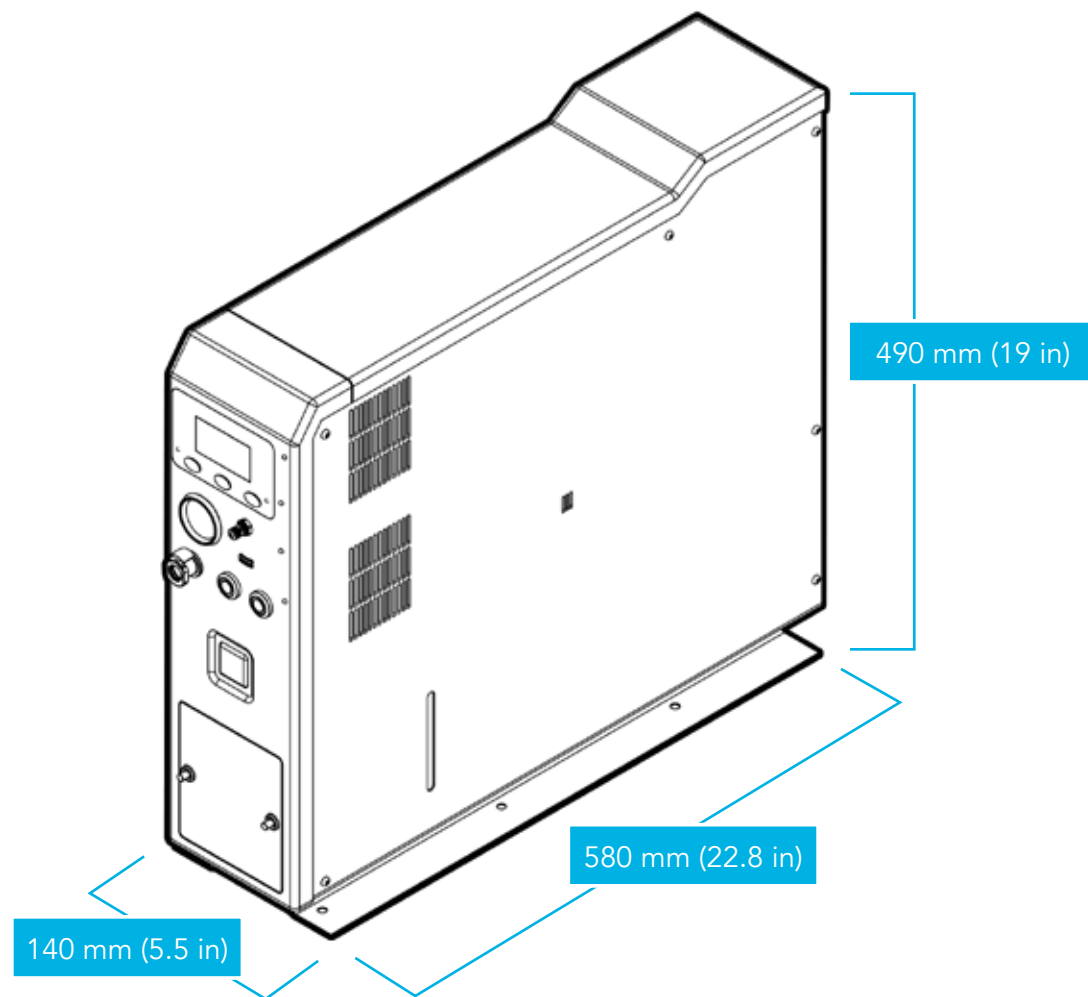

DESCRIPTION

The VICI DBS Zero Air option is available for select hydrogen generator models. When adding this option the gas generator will additionally remove all costly and inconvenient gas cylinders of zero grade air. In addition to cost savings, instrument sensitivity is improved, cleaning requirements of detectors are reduced, lab safety is enhanced and potential for ghost peaks and baseline drift are reduced.

MODELS & SPECS

	DB-FH-1800 or DB-FT-1800	DB-FH-5000 or DB-FT-5000
Flow mL/min	1800	5000
Purity - hydrocarbons + CO	<0.1 ppm	
Inlet pressure barg (psig)	4.5 to 10 (65 to 145)	
Inlet air quality	Clean dry compressed air ISO8573-1:2010 Class 1.2.1	
Max outlet pressure barg (psig)	5 (73)	
Max HC in	100 ppm	
Max CO in	50 ppm	
Technology	Platinum catalyst	
LED indicators	Power on/off, system ready, errors	
Warm up time minutes	45	
Electrical supply	110-120V 60Hz / 220-240V 50Hz	
Power consumption watts	200	550
Operating temperature °C (°F)	15 to 35 (59 to 95)	
Inlet connection	1/4" Compression	
Outlet connection	1/8" Compression	
Certification	CE, FCC, MET (UL and CSA compliant)	

OPTIONS:

DB-10156	I/O BOARD FOR NM & PG FID TOWER	DB-CASC-002	ON/OFF & NON-RETURN VALVE (HP)
DB-10157	CABLE FOR CASCADING (I/O BRD REQ)	DB-CASC-003	BUFFER RESERVOIR .75 LITERS (HP)
DB-PH200-107	REMOTE RS232 (I/O BRD REQ)	DB-CASC-004	PR WITH PRESSURE GAUGE
DB-PH200-108	REMOTE USB	DB-CASC-005	CASCADING HARDWARE KIT (HP)
DB-CASC-001	CASCADING HARDWARE KIT	DB-CASC-006	PR WITH PRESSURE GAUGE (HP)

CONSUMABLES:

DB-H200-031	DEIONIZER LE BAG (PACK OF 2 PCS.)
DB-FH200-013	COALESCENT FILTER AF10 WITH CARTRIDGE
DB-FH200-017	REPLACEMENT CARTRIDGE FOR COALESCENT FILTER AF10



COMPATIBLE MODELS HYDROGEN GENERATORS

- NM PLUS RACK
- PG PLUS RACK
- NM PLUS FID STATION (built in; flow option)
- PG PLUS FID STATION (built-in; flow option)
- NM PLUS FID TOWER (built-in; flow option)
- PG PLUS FID TOWER (built-in; flow option)

ORDERING INFORMATION (for best service, please call to discuss your application before placing your order).

NM & PG PLUS RACK

DB-RH-1800	Air Option 1.8 L/min
DB-RH-5000	Air Option 5.0 L/min

NM & PG PLUS FID STATION

DB-FH-1800	Air Option 1.8 L/min
DB-FH-5000	Air Option 5.0 L/min

NM & PG PLUS FID TOWER

DB-FT-1800	Air Option 1.8 L/min
DB-FT-5000	Air Option 5.0 L/min



NITROGEN GENERATORS

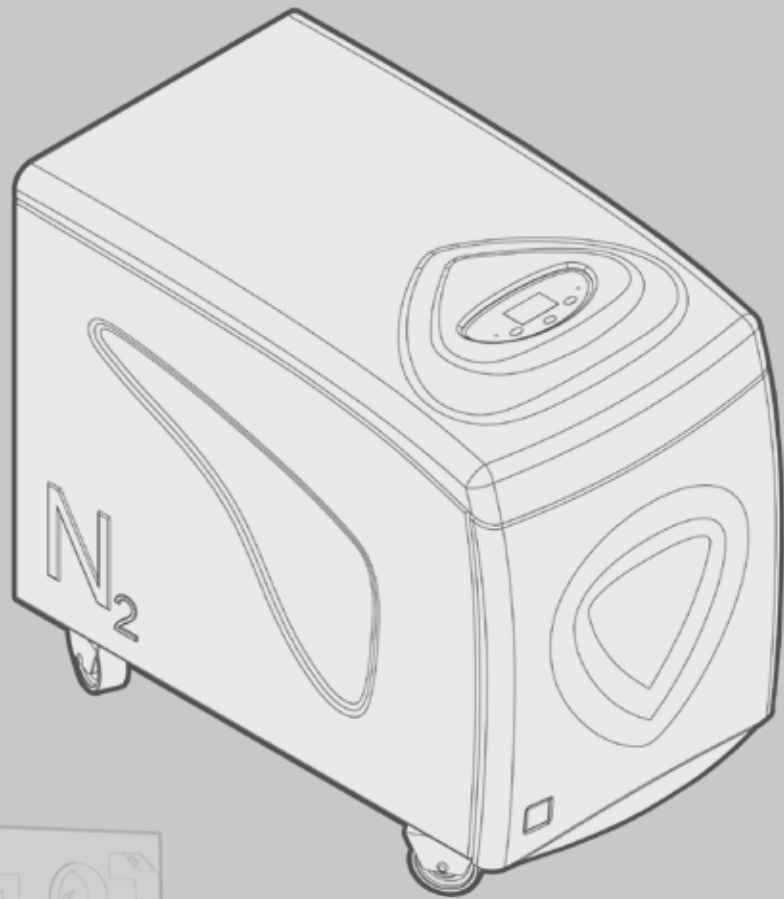

FEATURES

- Produce a continuous supply of nitrogen
- On-demand supply 24/7
- Carbon molecular sieve technology
- 2-year complete product warranty



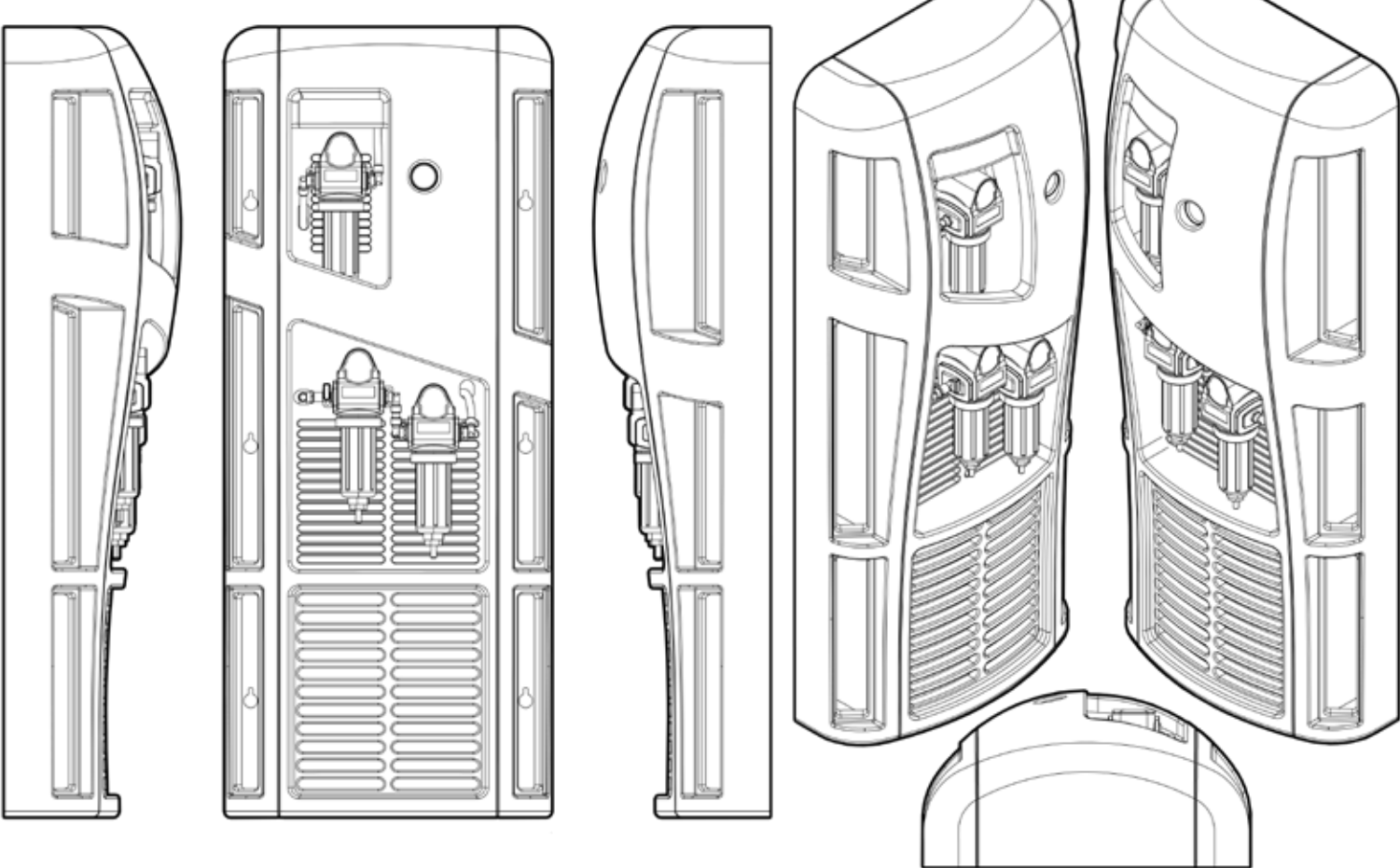
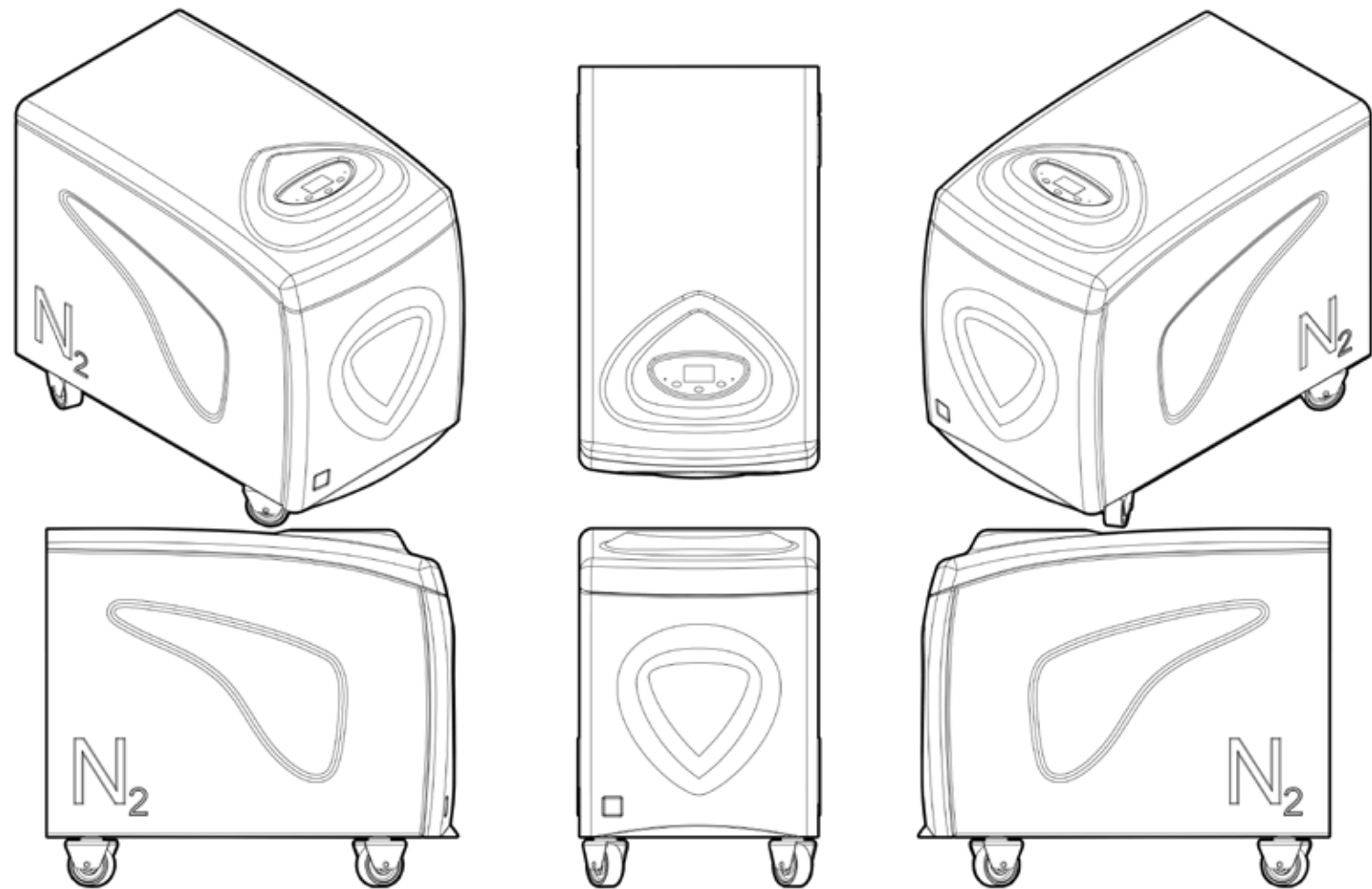

PRODUCT COMPARISON

	FLOW RATE	PURITY	PRESSURE - barg (psig)
MISTRAL EVOLUTION 10	10 L/min	>99.5%	3 (45)
MISTRAL EVOLUTION 25	25 L/min	99%	8 (116)
MISTRAL EVOLUTION 35	35 L/min	98%	8 (116)
MISTRAL EVOLUTION 40	40 L/min	97%	8 (116)
MISTRAL EVOLUTION HYBRID	12 L/min	>98%	5 (80)
MISTRAL EVOLUTION GAS STATION	25 L/min	99.5%	5.5 (80)
MINI WHISPER	12 L/min	97%	7 (100)
WHISPER-0 40	40 L/min	97%	7 (100)
WHISPER-0 80	80 L/min	97%	7 (100)
WHISPER-0 120	120 L/min	95%	7 (100)
MINI WHISPER HYBRID	12 L/min	99%	7 (100)
WHISPER-0 10 HYBRID	12 L/min	99%	7 (100)
WHISPER-0 40 HYBRID	40 L/min	97%	7 (100)
WHISPER-0 40 HYBRID PE	15 L/min	99%	7 (100)
WHISPER-0 80 HYBRID	80 L/min	97%	7 (100)
WHISPER-0 120 HYBRID	120 L/min	95%	7 (100)
HP PLUS TOWER 500	500 mL/min	>99.999%	5 (75)
HP PLUS TOWER 750	750 mL/min	>99.999%	5 (75)
HP PLUS TOWER 1300	1300 mL/min	99.99%	5 (75)
HP PLUS TOWER 4000	4000 mL/min	99%	5 (75)
HP PLUS TOWER 200 HC	200 mL/min	>99.999%	5 (75)
HP PLUS TOWER 500 HC	500 mL/min	>99.999%	5 (75)
HP PLUS TOWER 750 HC	750 mL/min	>99.999%	5 (75)
HP PLUS TOWER 1300 HC	1300 mL/min	99.99%	5 (75)
HP PLUS TOWER 4000 HC	4000 mL/min	99%	5 (75)
HP PLUS RACK 500	500 mL/min	>99.999%	5 (75)



MISTRAL EVOLUTION SERIES NITROGEN GENERATORS



FLOW RATE:
10 to 40 L/min



PURITY:
97 to 99.5%



PRESSURE:
7 to 8 barg (100 to 116 psig)



TECHNOLOGY:
Carbon Molecular Sieve

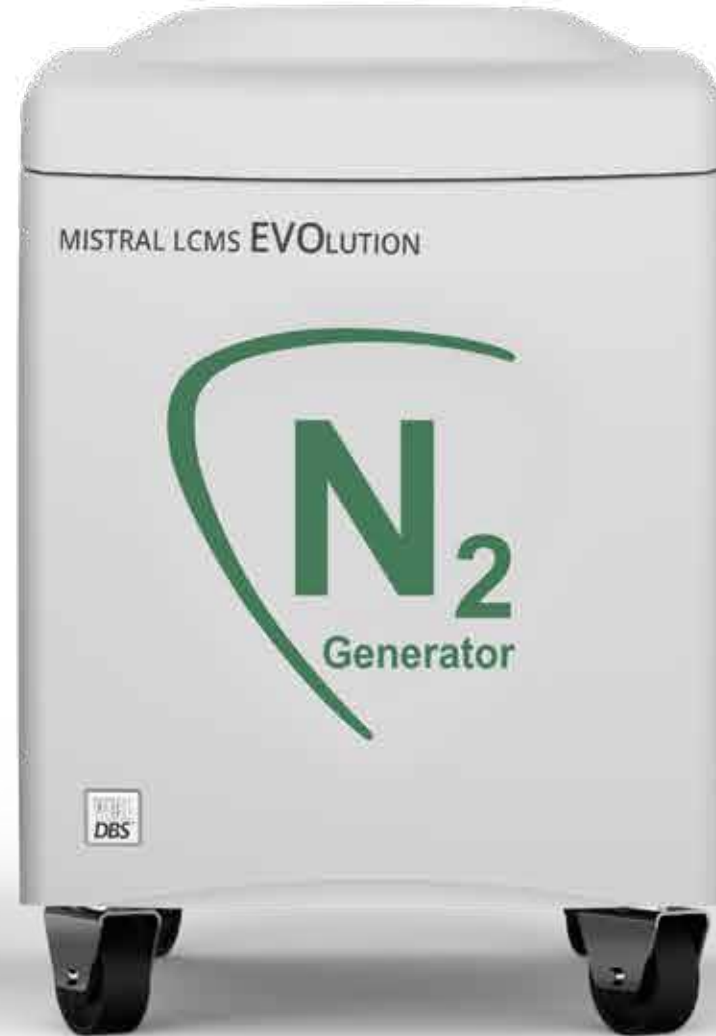

OPTIONS

- 10 liter tank
- 10 mt. tube



SUPERIOR TECHNOLOGY

The 2-stage pressure design allows the compressors to work at their optimum pressure range reducing the stress and results in extending the lifetime of the compressors. This reduces maintenance costs and associated downtime.

MISTRAL EVOLUTION NITROGEN GENERATOR

DESCRIPTION

The VICI DBS Mistral Evolution is a self-contained generator that produces up to 40 L/min of pure LC/MS grade nitrogen at up to 8 barg (116 psig). Nitrogen is produced by utilizing a combination of compressor and Carbon Molecular Sieve (CMS) technology. High and low-pressure compressors are carefully matched to the CMS demand to ensure quiet and reliable operation. This unique combination of dual compressor technology has several unique advantages over all other nitrogen generators commercially available.



APPLICATIONS

LC/MS INSTRUMENTS

- Nebulizing gas
- Curtain gas
- Shield gas
- Sheath gas
- Electrospray gas
- APCI gas
- Jet stream gradient

SPECTROSCOPY

- Nuclear magnetic resonance spectrometers (NMR)

ANALYZERS

- Thermal analyzers (TGA/DSC)

OTHER APPLICATIONS

- Sample concentrators
- Evaporative light scattering detector (ELSD)

- Corona detectors
- Charged aerosol (CAD)
- Sample evaporators
- Cell incubators
- IVF stem cell incubators
- Mask aligner
- Fume hood/cabinet purge
- 3D printer inerting
- Glove box purge

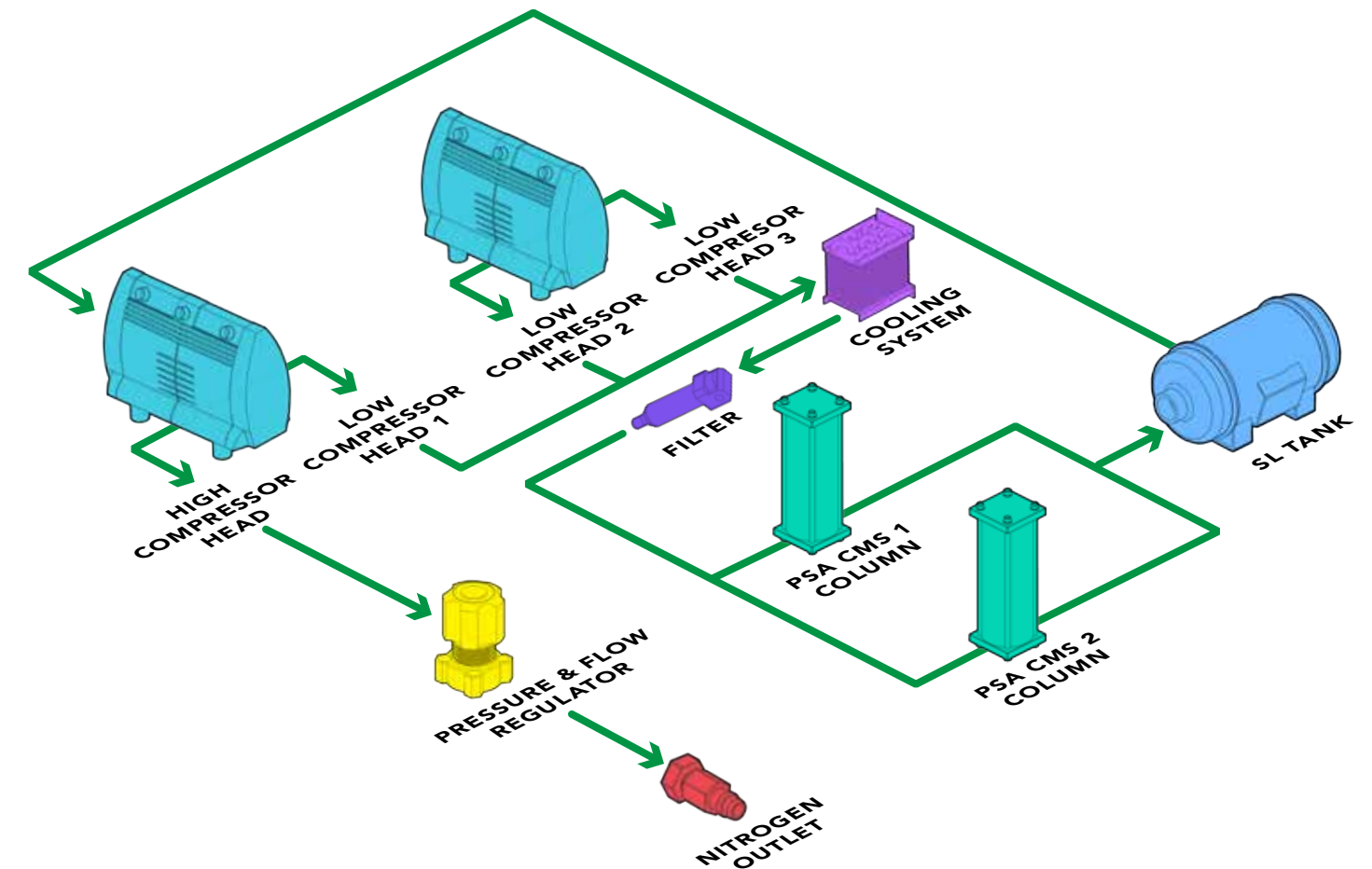

OPERATING DIAGRAM

The Mistral Evolution (PSA technology) includes two dynamically balanced, long-life compressors and delivers a continuous or on demand stream of pure nitrogen gas of 99.5% with a flow rate to 40 L/min.

It uses pressure swing adsorption (PSA) system which removes oxygen, carbon dioxide and water from compressed air. The resulting stream of pure nitrogen is ideal for LCMS instruments and other laboratory applications where inert gases are required.

MISTRAL EVOLUTION HYBRID NITROGEN + AIR GENERATOR

DESCRIPTION

The VICI DBS Mistral Evolution Hybrid is a self-contained generator that produces up to 12 L/min of high purity nitrogen and 22 L/min of air. The generator is designed to meet the specific requirements of the Sciex LC/MS instruments. Nitrogen and purified air are produced by utilizing a combination of compressor and Carbon Molecular Sieve (CMS) technologies. High and low-pressure compressors are carefully matched to the CMS demand to ensure quiet and reliable operation. This unique combination of dual compressor technology has several unique advantages over all other nitrogen generators commercially available.



UNIQUE BENEFITS

- Ideal for all Sciex LC/MS instruments

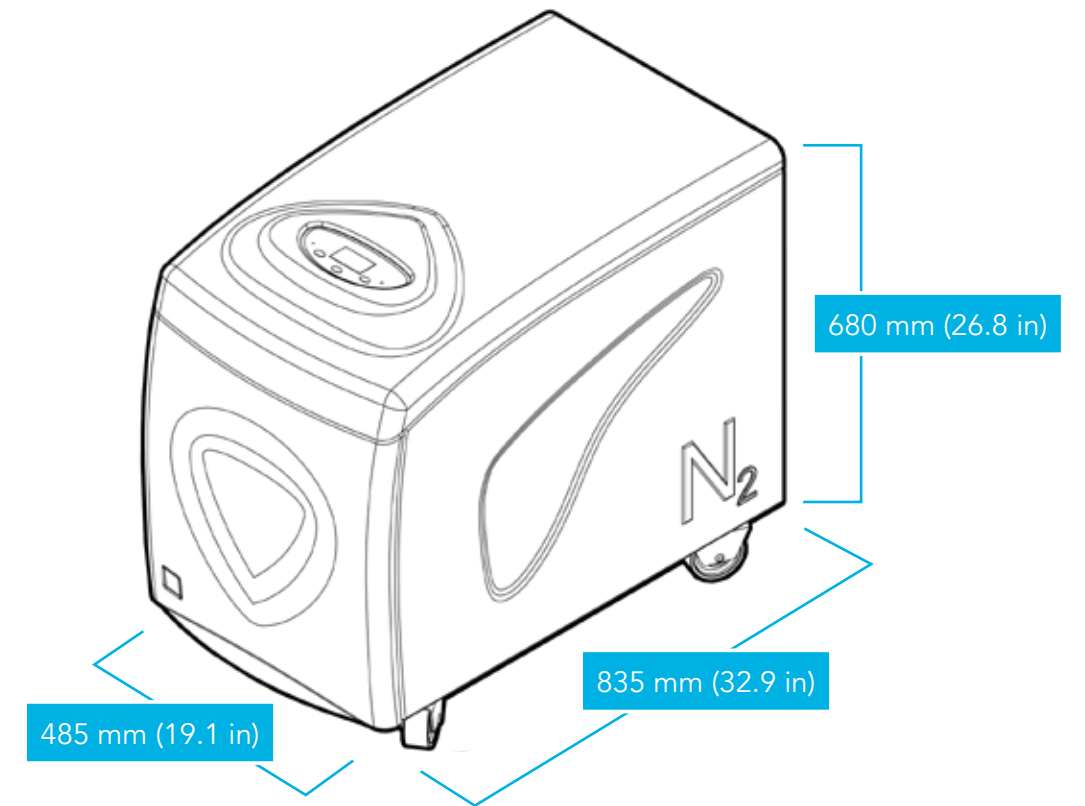

OPERATING DIAGRAM

The Mistral Evolution Hybrid (PSA technology) includes two dynamically balanced oil-free air compressors and delivers a continuous stream of pure nitrogen gas for curtain gas and purified air for gas 1 gas 2 and source exhaust.

Each Mistral uses a pressure swing adsorption (PSA) system which removes oxygen, carbon dioxide and water from compressed air. The output is a stream of pure nitrogen with clean, dry purified air for Sciex LC/MS instruments.

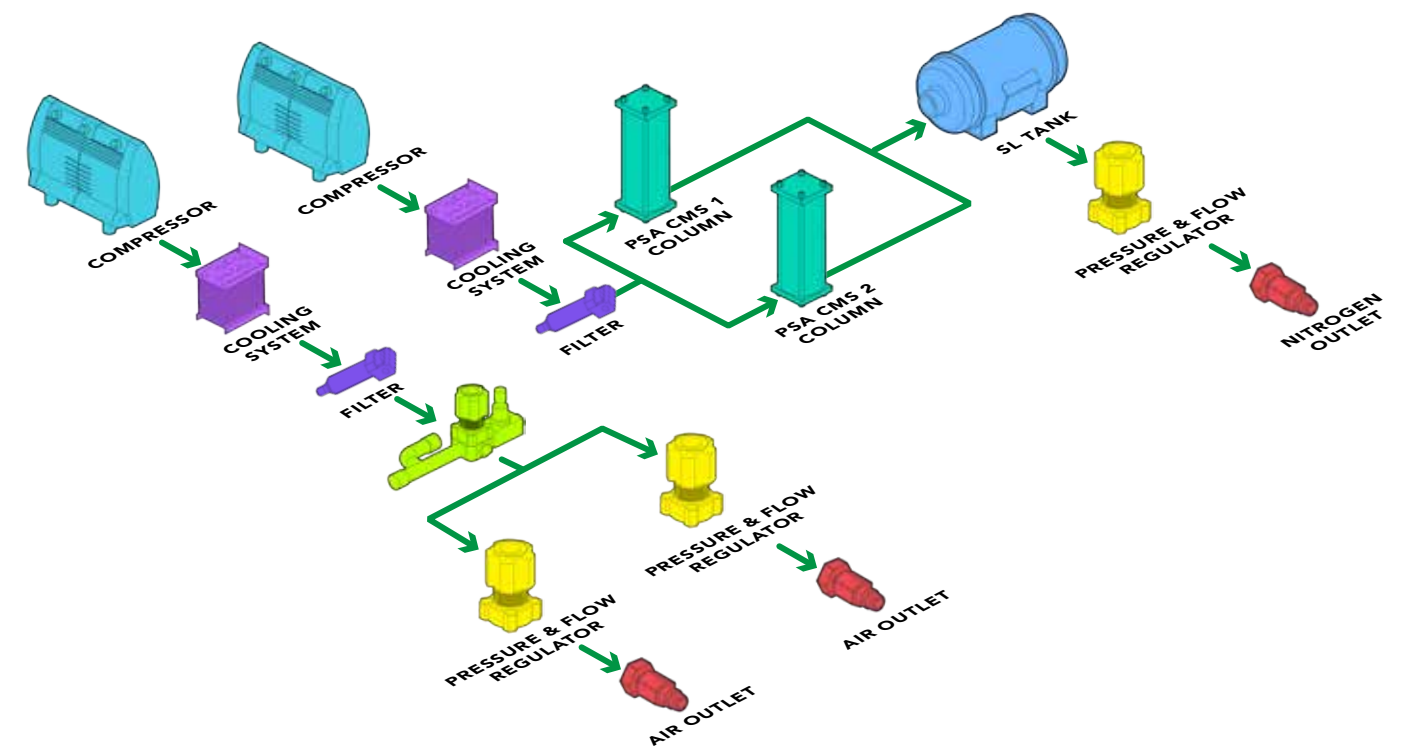

MISTRAL EVOLUTION GAS STATION NITROGEN + AIR GENERATOR

DESCRIPTION

The VICI DBS Mistral Evolution Gas Station is a self-contained generator that produces up to 25 L/min of pure nitrogen and 35 L/min of air specifically for the Agilent MP AES 4100 & 4200 instruments. Nitrogen is produced by utilizing a combination of compressor and Carbon Molecular Sieve (CMS) technology. High and low-pressure compressors are carefully matched to the CMS demand to ensure quiet and reliable operation. This unique combination of dual compressor technology has several unique advantages over all other nitrogen generators on the market.

Nitrogen is produced at low pressure, which ensures a longer compressor life and then compressed to 8 barg (116 psig) using a second stage compressor. This combination guarantees a long compressor life reducing maintenance costs and downtime. Air is produced using an additional third stage compressor maintaining a separate constant flow and pressure.



UNIQUE BENEFITS

- Ideal for Agilent MP AES applications

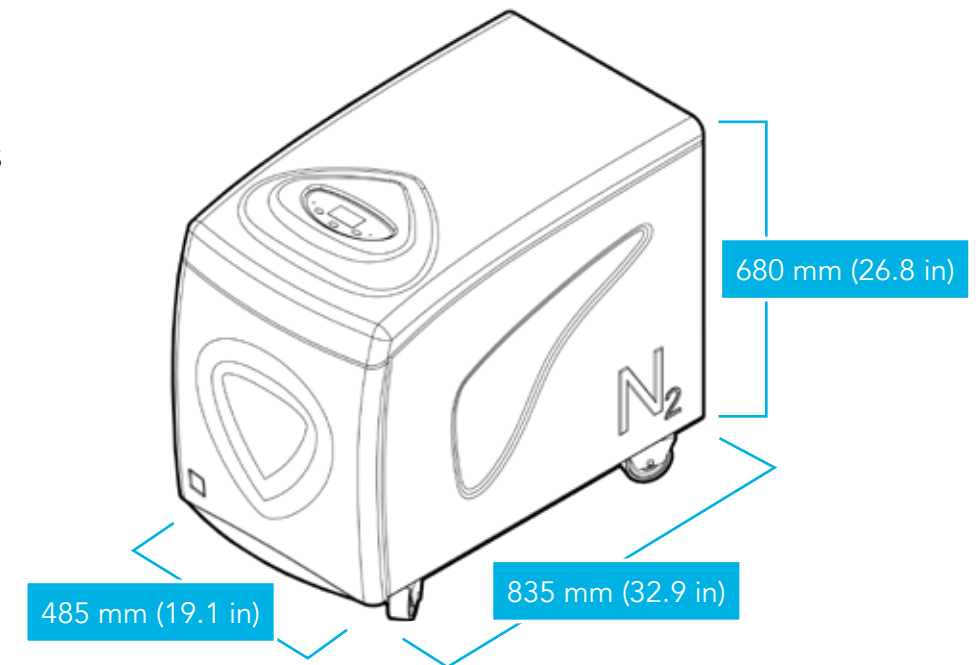

OPERATING DIAGRAM

Two integral oil-free compressors and a pressure swing adsorption system (PSA) produce 25 L/min of high purity nitrogen. In parallel an additional oil-free compressor and dryer are dedicated to the 35 L/min of dry air. With two separate outlets the generator is ideal to support the gas requirements of the Agilent MP AES systems.

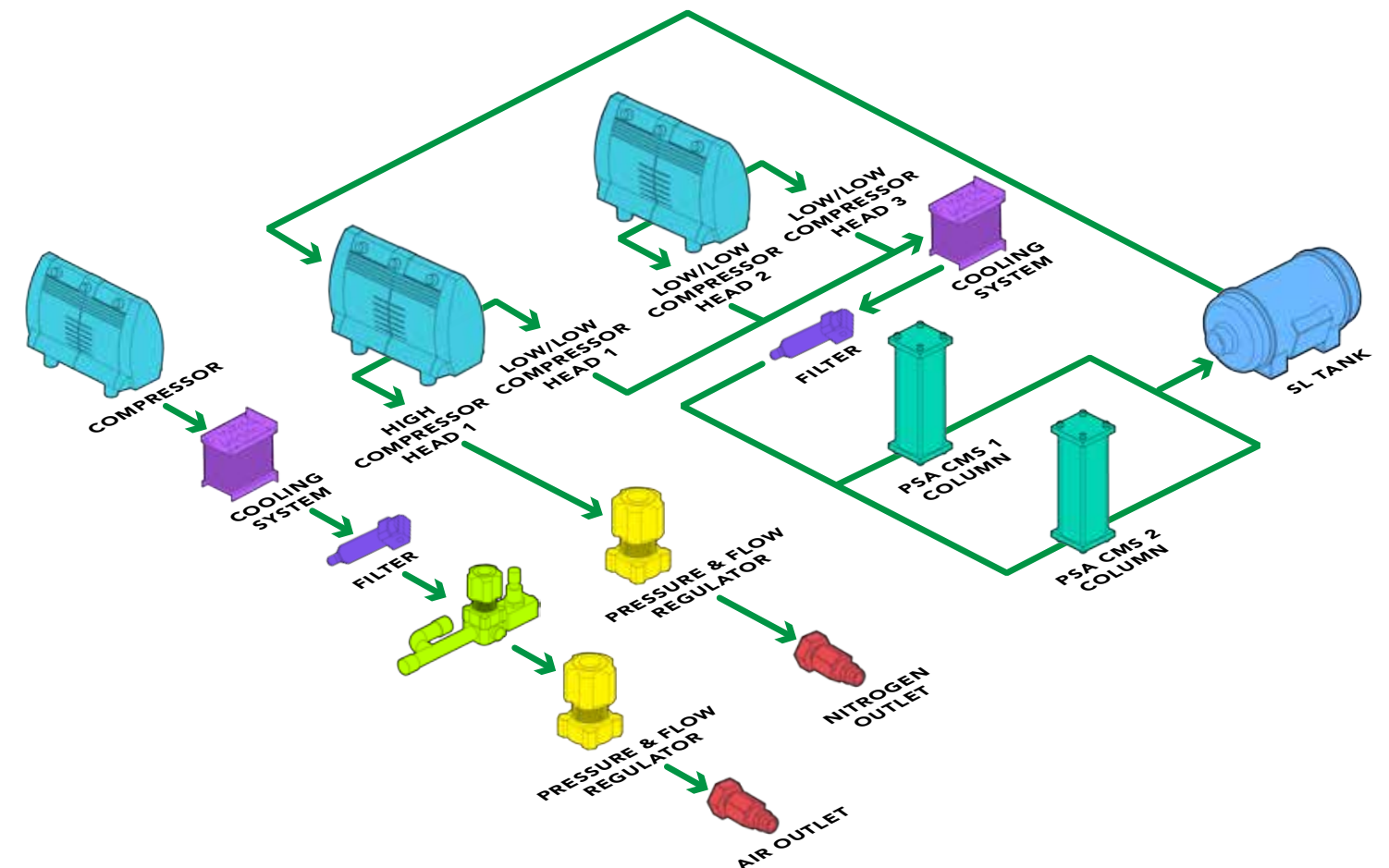

MODELS & SPECS	MISTRAL EVOLUTION 10	MISTRAL EVOLUTION 25	MISTRAL EVOLUTION 35	MISTRAL EVOLUTION 40
Nitrogen flow rate L/min	10	25	35	40
Nitrogen purity	>99.5%	99%	98%	97%
Dew point °C (°F)	-50 (-58)			
Outlet pressure barg (psig)	3 (45)	8 (116)		
Technology	Carbon molecular sieve			
Warm up time minutes	20			
LED indicators	Power on/off, system ready, errors			
Electricity supply	110-120V 60Hz / 220-240V 50Hz			
Power consumption watts	1800			
Noise level	55 dBA @ 1 meter			
Dimensions mm (in)	485W x 680H x 835D (19.1W x 26.8H x 32.9D)			
Weight kg (lb)	90 (198)			
Shipping dimensions mm (in)	950W x 560H x 930D (37.4W x 22H x 36.6D)			
Shipping weight kg (lb)	115 (254)			
Operating temp °C (°F)	15 to 35 (59 to 95)			
Outlet connection	6 mm OD compression or 1/4"			
Certification	CE, FCC, MET (UL and CSA compliant)			

OPTIONS:

DB-WN2-005 10 LITER TANK

DB-WN2-006 10 MT. TUBE

CONSUMABLES:

DB-FIL010 KIT FOR MISTRAL EVO LOW NOISE

DB-EVO-011 OF-332 AIR COMPRESSOR (NITROGEN)

DB-EVO-010 OF-312 AIR COMPRESSOR (AIR)

MISTRAL EVOLUTION 10

DB-EVO-10-EU 220V/50Hz

DB-EVO-10-US 115V/60Hz

MISTRAL EVOLUTION 35

DB-EVO-35-EU 220V/50Hz

DB-EVO-35-US 115V/60Hz

MISTRAL EVOLUTION HYBRID

DB-EVO-HY-EU 220V/50Hz

DB-EVO-HY-US 110V/60Hz

MISTRAL EVOLUTION 25

DB-EVO-25-EU 220V/50Hz

DB-EVO-25-US 115V/60Hz

MISTRAL EVOLUTION 40

DB-EVO-40-EU 220V/50Hz

DB-EVO-40-US 115V/60Hz

MISTRAL EVOLUTION GAS STATION

DB-EVO-GS-EU 220V/50Hz

DB-EVO-GS-US 115V/60Hz

MODELS & SPECS

MODELS & SPECS	MISTRAL EVOLUTION HYBRID
Nitrogen flow rate L/min	12 @ 5 barg (80 psig)
Air 1 - flow rate L/min	8 @ 4 barg (60 psig)
Air 2 - flow rate L/min	24 @ 7 barg (100 psig)
Nitrogen purity	>98%
Dew point °C (°F)	-50 (-58)
Outlet pressure barg (psig)	7 (100)
Technology	Carbon molecular sieve
Warm up time minutes	20
Electrical supply	110-120V 60Hz / 220-240V 50Hz
Power consumption watts	1800
Noise level	55 dBA @ 1 meter
Dimensions mm (in)	485W x 680H x 835D (19.1W x 26.8H x 32.9D)
Weight kg (lb)	90 (198)
Shipping dimensions mm (in)	950W x 560H x 930D (37.4W x 22H x 36.6D)
Shipping weight kg (lb)	115 (254)
Operating temp °C (°F)	15 to 35 (59 to 95)
Outlet connections	3 x 6 You gomm OD Compression or 1/4"
Certification	CE, FCC, MET (UL and CSA compliant)

MODELS & SPECS

MODELS & SPECS	MISTRAL EVOLUTION GAS STATION
Nitrogen flow rate L/min	25 @ 5.5 barg (80 psig)
Air 1 - flow rate L/min	35 @ 5.5 barg (80 psig)
Nitrogen purity	99.5%
Dew point °C (°F)	-40 (-40)
Outlet pressure barg (psig)	7 (100)
Technology	Carbon molecular sieve
Warm up time minutes	20
Electrical supply	110-120V 60 Hz / 220-240V 50Hz
Power consumption watts	2700
Noise level	55 dBA @ 1 meter
Dimensions mm (in)	482W x 641H x 1235D (18.9W x 25H x 48D)
Weight kg (lb)	110 (243)
Shipping dimensions mm (in)	550W x 800H x 940D (21.6W x 31.4H x 37D)
Shipping weight kg (lb)	141 (311)
Operating temp °C (°F)	15 to 35 (59 to 95)
Outlet connection	2 x 6mm OD compression or 1/4"
Certification	CE, FCC, MET (UL and CSA compliant)



WHISPER-0 SERIES NITROGEN GENERATORS



FLOW RATE:
12 to 120 L/min



PURITY:
95 to 99%



PRESSURE:
7 barg (100 psig)



TECHNOLOGY:
Membrane



DESCRIPTION

The VICI DBS Whisper-0 nitrogen generators can produce up to 120 L/min of high purity LC/MS grade nitrogen at pressures up to 8 barg (116 psig). These generators are engineered to transform standard compressed air into a safe regulated nitrogen supply with minimal operator attention and maintenance. Nitrogen is produced by utilizing a combination of filtration and membrane separation technologies. A standard supply of compressed air is filtered by high efficiency coalescing filters to remove all contaminants down to 0.1 micron. A unique proprietary membrane then separates the air into a concentrated nitrogen stream.

Membrane technology offers many unique performance benefits for LC/MS users including phthalate-free nitrogen, silent operation, no moving parts, and no electrical requirements. The generators can be installed directly in the laboratory with the Whisper-0 mounting to the wall and the Whisper-0 Mini to the floor. Both require minimal operator attention or maintenance. The generators are designed to run continuously or on-demand providing a clean, dry high purity nitrogen supply.



SUPERIOR TECHNOLOGY

VICI DBS membrane nitrogen generators require no electricity, have no moving parts and minimal noise.



APPLICATIONS

LC/MS INSTRUMENTS

- Nebulizing gas
- Curtain gas
- Shield gas
- Sheath gas
- Electrospray gas
- APCI gas
- Jet stream gradient

SPECTROSCOPY

- Nuclear magnetic resonance spectrometers (NMR)

ANALYZERS

- Thermal analyzers (TGA/DSC)

OTHER APPLICATIONS

- Sample concentrators
- Evaporative light scattering detector (ELSD)

- Corona detectors
- Charged aerosol (CAD)
- Sample evaporators
- Cell incubators
- IVF Stem Cell incubators
- Mask aligner
- Fume hood/cabinet purge
- 3D printer inerting
- Glove box purge

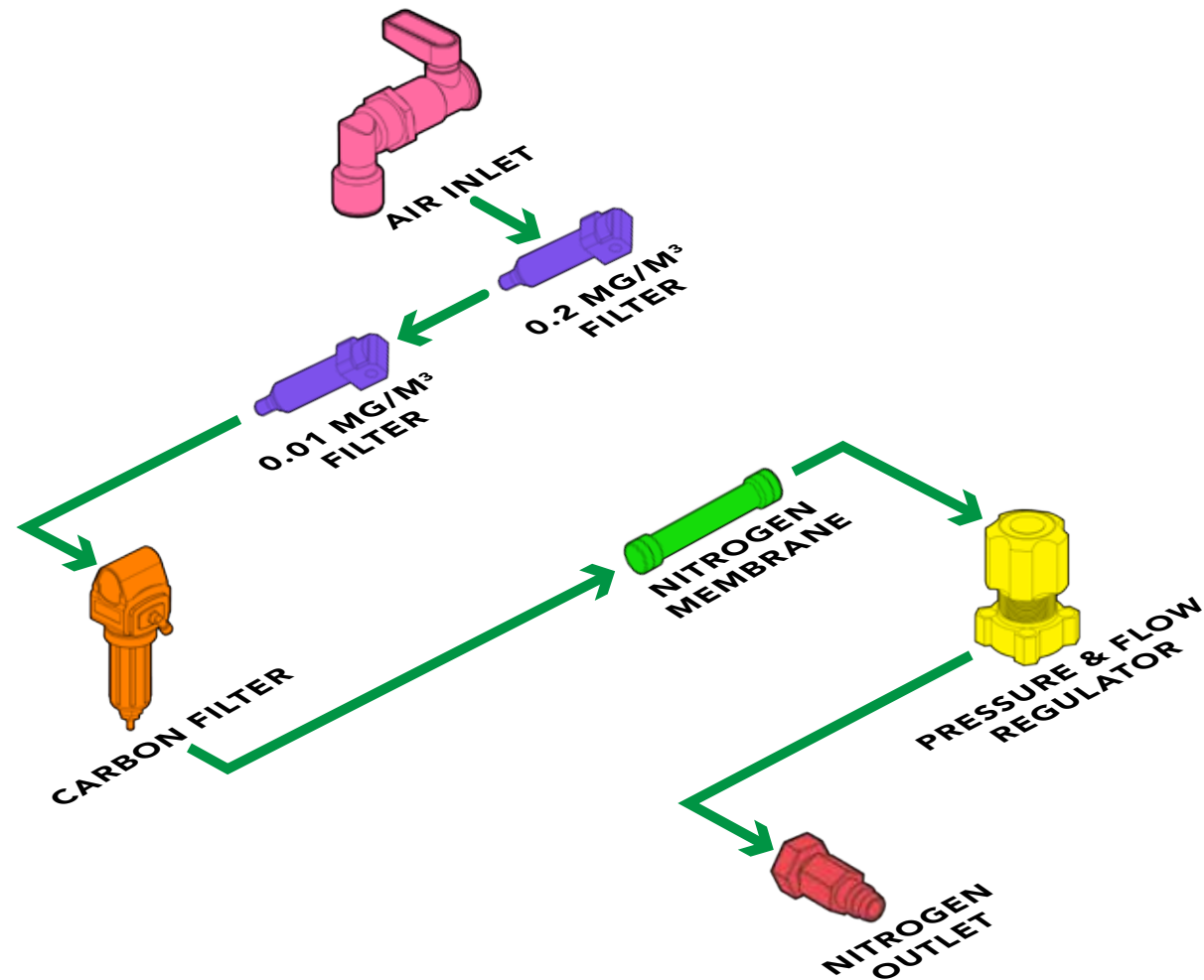

OPERATING DIAGRAM

Nitrogen is produced from compressed air by the principle of selective permeation across the nitrogen module. The membrane module consists of a compacted group of hollow fiber tubes which are permeable to different gases. The "fast" gases (oxygen, carbon dioxide, and water vapor) permeate the membrane wall much faster than the "slow" gas (nitrogen). The membrane separates the original gas mixture into two streams: the permeate which is lost to the atmosphere and a stream of high purity nitrogen.



MODELS & SPECS

	MINI WHISPER	WHISPER-0 40	WHISPER-0 80	WHISPER-0 120
Flow L/min	12	40	80	120
Purity	99% & 12 L/min 99% & 10 L/min	97% @ 40 L/min 99% @ 20 L/min	97% @ 80 L/min 98% @ 50 L/min	95% @ 120 L/min 98% @ 50 L/min
Dew point °C (°F)	-50 (-58)			
Outlet pressure barg (psig)	7 (100)			
Inlet pressure barg (psig)	8.5 to 10 (123 to 160)			
Actual inlet air requirement liters	25	120	210	245
Recommended compressor air inlet	120	240	420	490
Pressure drop barg (psig)	1.5 (22)			
Inlet air quality	Clean dry compressed air ISO8573-1:2010 Class 1.2.1			
Technology	Membrane			
Warm up time minutes	None			
Electrical supply	None			
Noise level	None			
Dimensions mm (in)	348W x 735H x 180D (13.7W x 29H x 7.1D)	480W x 1150H x 300D (18.9W x 45.3H x 11.8D)		
Weight kg (lb)	8 (17.6)	15 (33)	18 (40)	20 (44)
Shipping dimensions mm (in)	900W x 560H x 480D (35.4W x 22H x 18.9D)	1295W x 485H x 640D (51W x 19.1H x 25.2D)		
Shipping weight kg (lb)	14 (31)	22 (49)	27 (60)	27 (60)
Operating temp °C (°F)	15 to 35 (59 to 95)			
Inlet connection	3/8" G			
Outlet connection	1/4" Compression			
Certification	CE			

OPTIONS:

- DB-WN2-005** 10 LITER TANK
- DB-WN2-006** 10 MT. TUBE
- DB-WN2-017** SPECIAL 100% TEFLON TUBING (ANY MODEL)

CONSUMABLES:

- DB-WN2-001** ANNUAL FILTER KIT (3 FILTER ELEMENTS)



UNIQUE BENEFITS

- Ideal for all LC/MS applications
- Reduces compressed air consumption and cost
- Superior air purification with long life membrane



OPTIONS

- 10 liter tank
- 10 mt. tube
- Special 100% teflon tubing

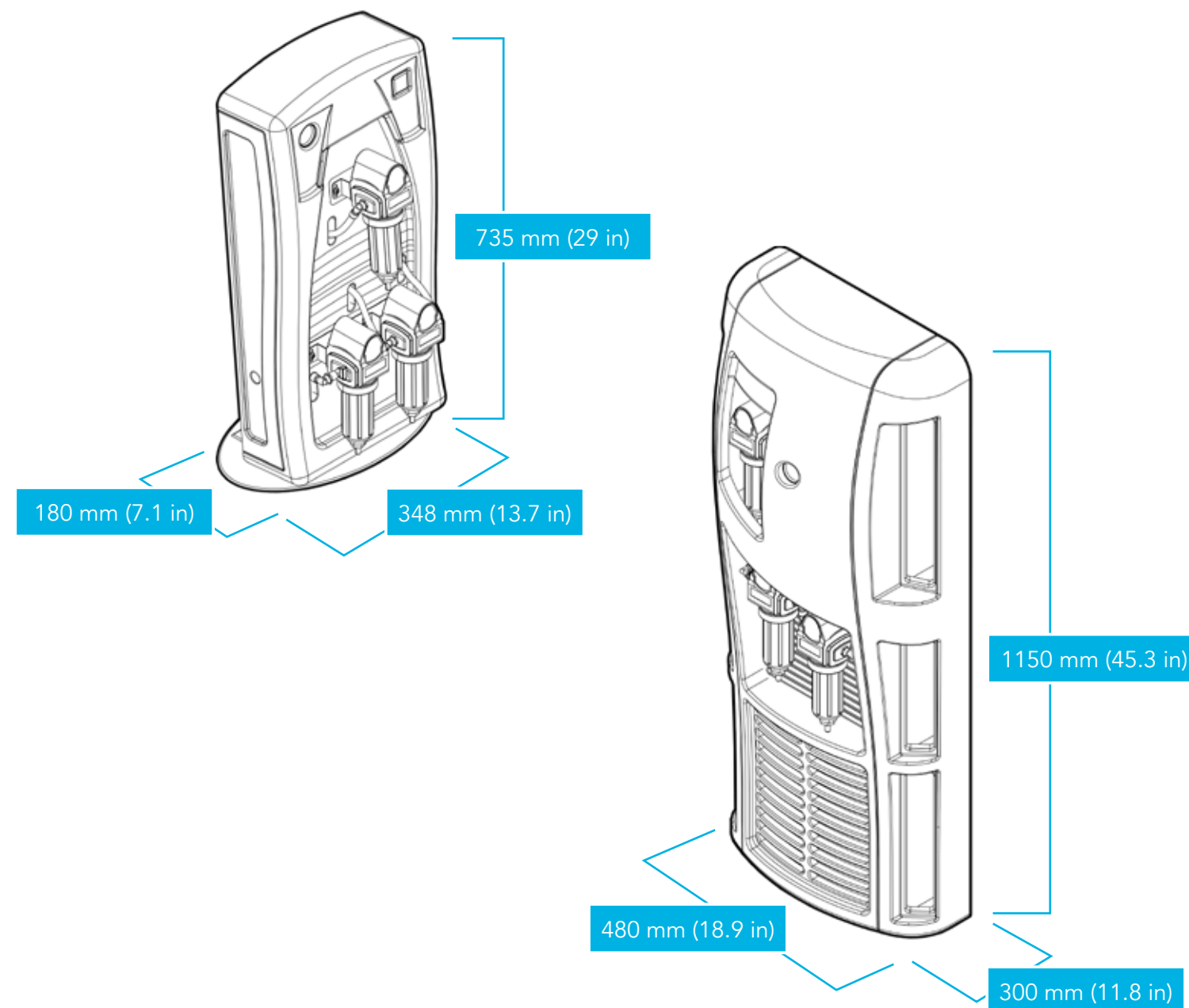

ORDERING INFORMATION (for best service, please call to discuss your application before placing your order).

MINI WHISPER

DB-MWN2-10

WHISPER-0 40

DB-WN2-0-40

WHISPER-0 80

DB-WN2-0-80

WHISPER-0 120

DB-WN2-0-120



WHISPER-0 HYBRID SERIES NITROGEN + AIR GENERATORS



FLOW RATE:
12 to 120 L/min



PURITY:
95 to 99%



PRESSURE:
7 barg (100 psig)



TECHNOLOGY:
Membrane



DESCRIPTION

The VICI DBS Whisper-0 Hybrid Nitrogen + Air can produce up to 120 L/min of high purity LC/MS grade nitrogen at pressures up to 8 barg (116 psig). These generators are engineered to transform standard compressed air into a safe regulated nitrogen and high purity air supply with minimal operator attention and maintenance. Nitrogen is produced by utilizing a combination of filtration and membrane separation technologies. A standard supply of compressed air is filtered by high efficiency coalescing filters to remove all contaminants down to 0.1 micron. A unique proprietary membrane then separates the air into a concentrated nitrogen stream. Air is purified using a unique air purification membrane removing contamination and water.

Membrane technology offers some unique performance benefits for LC/MS users including phthalate-free nitrogen, silent operation, no moving parts, and no electrical requirements. The generator can be installed directly in the laboratory either floor or walled mounted and requires minimal operator attention or maintenance. The generators are designed to run continuously providing a clean, dry high purity nitrogen supply.



SUPERIOR TECHNOLOGY

The VICI DBS membrane nitrogen generators require no electricity, have no moving parts and minimal noise.

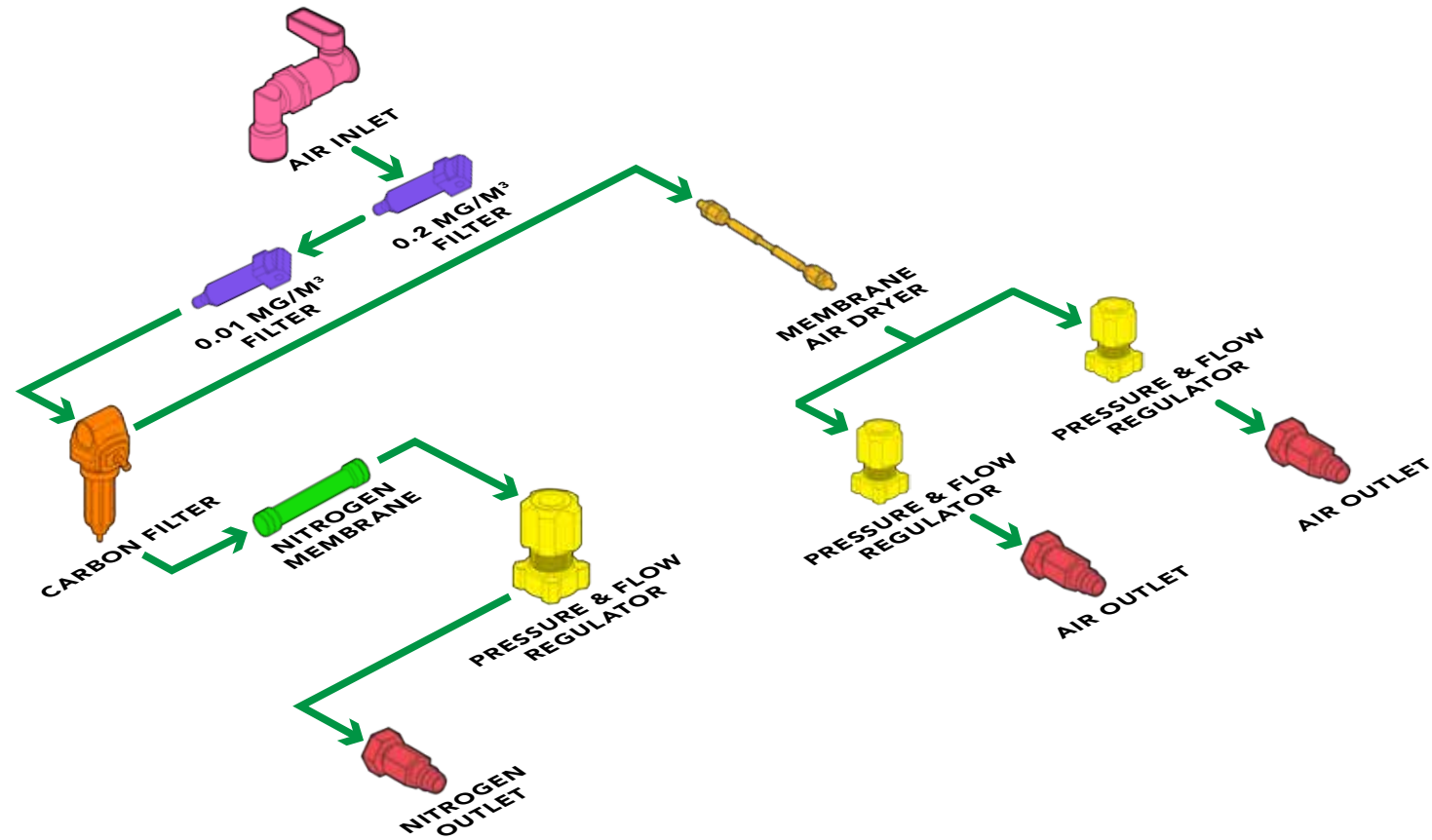

- APPLICATIONS**
LC/MS INSTRUMENTS
- Sciex
 - Shimadzu
 - Perkin Elmer
 - Shield gas
 - Sheath gas
 - Electrospray gas
 - Nebulizing gas



- UNIQUE FEATURES**
- Produces a continuous supply of high purity nitrogen and air for Sciex, Shimadzu and Perkin Elmer LC/MS
 - Integrated economy mode as standard
 - Proprietary membrane technology
 - No noise, no moving parts, and no electricity

WHISPER-0 HYBRID OPERATING DIAGRAM

Nitrogen is produced from compressed air by the principle of selective permeation across the nitrogen module. The membrane module consists of a compacted group of hollow fiber tubes which are permeable to different gases. The “fast” gases (oxygen, carbon dioxide, and water vapor) permeate the membrane wall much faster than the “slow” gas (nitrogen). The membrane separates the original gas mixture into two streams: the permeate which is lost to the atmosphere and a stream of high purity nitrogen.

In addition part of the compressed air is purified using a separate selective drying membrane. The membrane separates the original gas mixture into two streams: the permeate which is lost to the atmosphere and a stream of dry high purity air.



MODELS & SPECS

	MINI WHISPER-0 HYBRID	WHISPER-0 10 HYBRID	WHISPER-0 40 HYBRID	WHISPER-0 40 HYBRID PE	WHISPER-0 80 HYBRID	WHISPER-0 120 HYBRID
Curtain gas flow rate L/min - nitrogen	12 @ 7 barg (100 psig)	12 @ 7 barg (100 psig)	40 @ 7 barg (100 psig)	15 @ 7 barg (100 psig)	80 @ 7 barg (100 psig)	120 @ 7 barg (100 psig)
Exhaust gas flow rate L/min - dry air	10 @ 4 barg (60 psig)	10 @ 4 barg (60 psig)	25 @ 4 barg (60 psig)	n/a	25 @ 4 barg (60 psig)	25 @ 4 barg (60 psig)
Source gas flow rate L/min - dry air	26 @ 7 barg (100 psig)	26 @ 7 barg (100 psig)	22 @ 7 barg (100 psig)	70 @ 7 barg (100 psig)	22 @ 7 barg (100 psig)	22 @ 7 barg (100 psig)
Nitrogen purity at max flow rate	99%	99%	97%	99%	97%	95%
Dew point °C (°F)	-40 (-40)					
Outlet pressure barg (psig)	7 (100)					
Inlet pressure barg (psig)	8.5 to 10 (123 to 160)					
Actual inlet compressed air requirement L/min	96	96	197	220	297	347
Recommended comp. air inlet requirement (L/min)	192	192	394	440	594	694
Pressure drop barg (psig)	1.5 (22)					
Inlet air quality	Clean dry compressed air ISO8573-1:2010 Class 1.2.1					
Technology	Membrane					
Warm up time minutes	None					
Electrical supply	None					
Noise level	None					
Product dimensions mm (in)	348W x 735H x 180D (13.7W x 29H x 7.1D)	480W x 1150H x 300D (18.9W x 45.3H x 11.8D)				
Product weight kg (lb)	8 (17.6)	15 (33)	25 (55)	25 (55)	30 (66)	30 (66)
Shipping dimensions mm (in)	900W x 560H x 480D (35.4W x 22H x 18.9D)	1295W x 485H x 640D (51W x 19.1H x 25.2D)				
Shipping weight kg (lb)	12 (27)	22 (49)	32 (71)	32 (71)	37 (82)	37 (82)
Operating temp °C (°F)	15 to 35 (59 to 95)					
Inlet connection	3/8" G					
Outlet connection	6 mm or 1/4" OD Compression					
Certification	CE					

OPTIONS:

DB-WN2-005	10 LITER TANK
DB-WN2-006	10 MT. TUBE
DB-WN2-017	SPECIAL 100% TEFLON TUBING (ANY MODEL)

CONSUMABLES:

DB-WN2-001	ANNUAL FILTER KIT (3 FILTER ELEMENTS)
-------------------	---------------------------------------

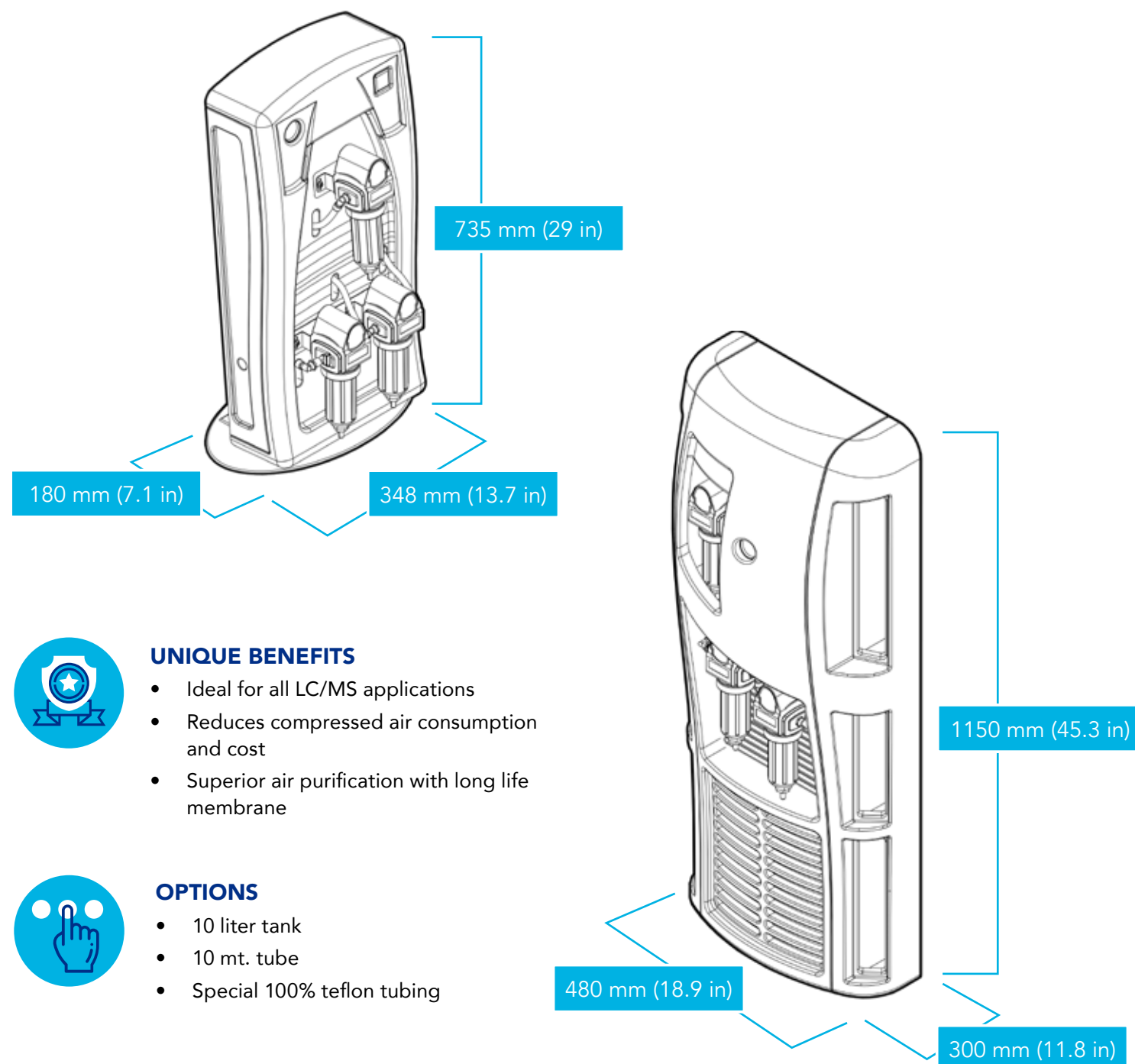

ORDERING INFORMATION (for best service, please call to discuss your application before placing your order).

MINI WHISPER HYBRID

DB-MWN2-HY

WHISPER-0 10 HYBRID

DB-WN2-0-10-HY

WHISPER-0 40 HYBRID

DB-WN2-0-40-HY

WHISPER 0-40 HYBRID PE

SINGLE: DB-WN2-0-40-HY-P-E-S
DUAL: DB-WN2-0-40-HY-P-E-D

WHISPER 0-80 HYBRID

DB-WN2-0-80-HY

WHISPER 0-120 HYBRID

DB-WN2-0-120-HY



HP PLUS TOWER NITROGEN GENERATOR



FLOW RATE:
200 to 4000 mL/min



PURITY:
99 to >99.999%



PRESSURE:
5 barg (75 psig)



TECHNOLOGY:
Carbone Molecular Sieve



DESCRIPTION

The VICI DBS HP Plus Tower produces nitrogen by utilizing a combination of filtration and pressure swing adsorption (PSA) technology. Standard compressed air is filtered by high efficiency coalescing filters to remove all contaminants down to 5 micron. For ultra-sensitive applications such as GC carrier and make-up gas, units also include the additional heated catalyst module to ensure hydrocarbons are removed to <0.1 ppm. The air then passes through two columns filled with a proprietary blended carbon molecular sieve (CMS) which adsorbs O₂, CO₂, and moisture. These are desorbed to the atmosphere during the pressure swing cycle leaving a supply of ultra-pure nitrogen.

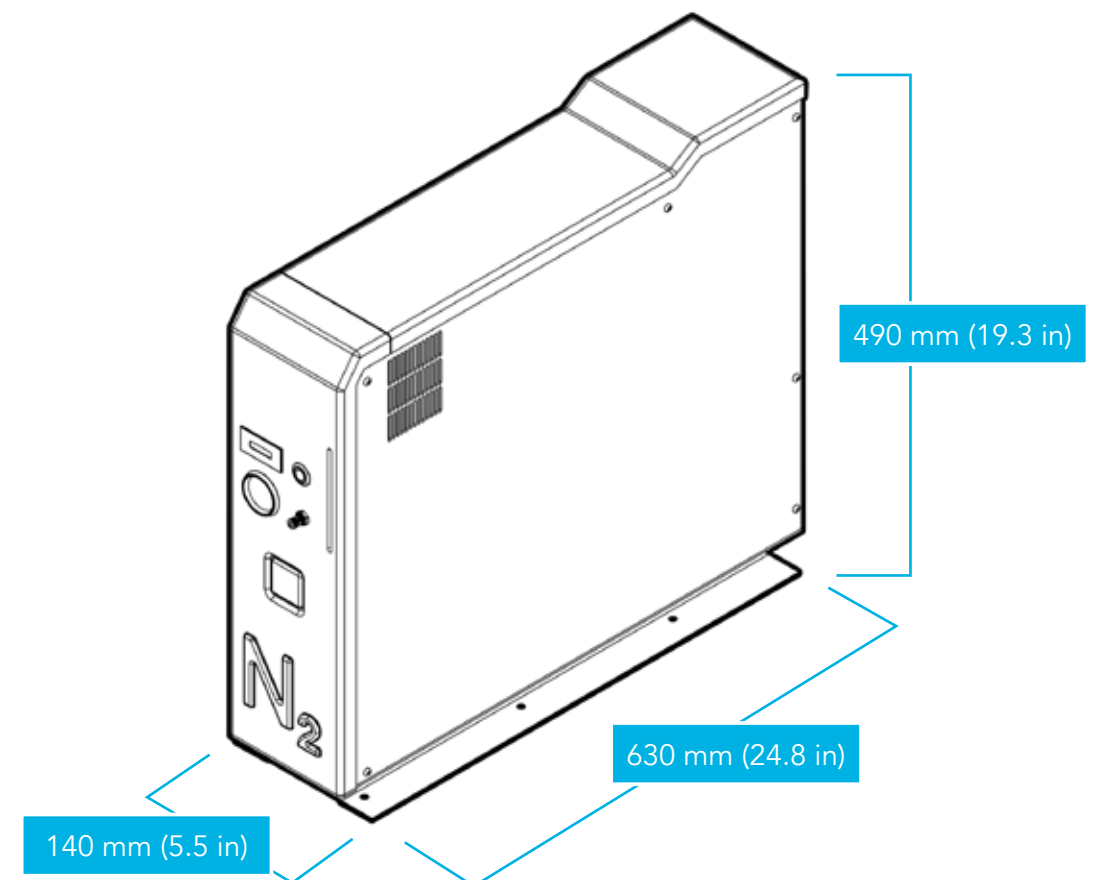

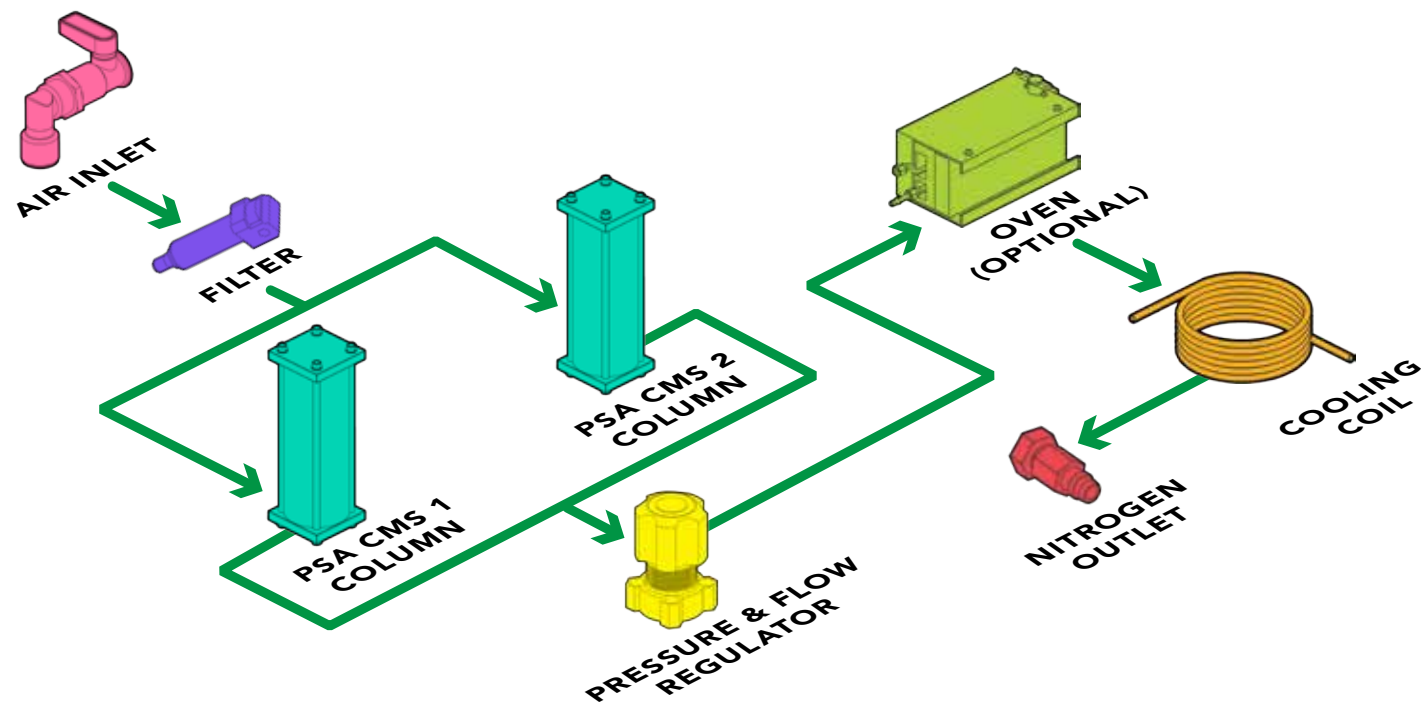

APPLICATIONS

GC APPLICATIONS

- GC carrier and make-up gas
- ECD
- ELSD

- TGA & DSC
- Incubators

OPERATING DIAGRAM

Standard compressed air is filtered by high efficiency coalescing filters to remove all contaminants down to 5 micron. For ultra-sensitive applications such as GC carrier and make-up gas, units also include the additional heated catalyst module to ensure hydrocarbons are removed to <0.1 ppm. The air then passes through two columns filled with a proprietary blended carbon molecular sieve (CMS) which adsorbs O₂, CO₂, and moisture. These are desorbed to the atmosphere during the pressure swing cycle leaving a supply of ultra-pure nitrogen.



MODELS & SPECS	HP PLUS 500	HP PLUS 750	HP PLUS 1300	HP PLUS 4000
Flow mL/min	500	750	1300	4000
Purity	>99.999%		99.99%	99%
Hydrocarbon purity (measured as methane)	n/a			
Dew point °C (°F)	-50 (-58)			
Outlet pressure barg (psig)	up to 5 max (75)			
Inlet pressure barg (psig)	7 to 10 (100 to 160)			
Actual inlet air requirement litres @ 8 barg	11	12	16	24
Recommended compressor air inlet @ 8 barg	22	24	32	48
Pressure drop barg (psig)	1.5 (22)			
Inlet air quality	Clean dry compressed air ISO8573-1:2010 Class 1.2.1			
Technology	Carbon molecular sieve			
Warm up time minutes	60			
LED indicators	Power on/off, system ready, errors			
Electrical supply	110-120V 60Hz / 220-240V 50 Hz			
Power consumption watts	12			
Noise level	Minimal			
Dimensions mm (in)	140W x 490H x 630D (5.5W x 19.3H x 24.8D)			
Weight kg (lb)	15 (17.6)			
Shipping dimensions mm (in)	770W x 590H x 410D (30.3W x 16.1H x 23.2D)			
Shipping weight kg (lb)	20 (44)			
Operating temp °C (°F)	15 to 35 (59 to 95)			
Inlet connection	1/4" Compression			
Outlet connection	1/8" Compression			
Certification	CE, FCC			

MODELS & SPECS	HP PLUS 200 HC	HP PLUS 500 HC	HP PLUS 750 HC	HP PLUS 1300 HC	HP PLUS 4000 HC
Flow mL/min	200	500	750	1300	4000
Purity	>99.999%			99.99%	99%
Hydrocarbon purity (measured as methane)	0.1 ppm				
Dew point °C (°F)	-50 (-58)				
Outlet pressure barg (psig)	Up to 5 max (75)				
Inlet pressure barg (psig)	7 to 10 (100 to 160)				
Actual inlet air requirement liters @ 8 barg	11	11	12	16	24
Recommended compressor air inlet @ 8 barg	22	22	24	32	48
Pressure drop barg (psig)	1.5 (22)				
Inlet air quality	Clean dry compressed air ISO8573-1:2010 Class 1.2.1				
Technology	Carbon molecular sieve				
Warm up time minutes	60				
LED indicators	Power on/off, system ready, errors				
Electrical supply	110-120V 60Hz / 220-240V 50 Hz				
Power consumption watts	270				
Noise level	Minimal				
Dimensions mm (in)	140W x 490H x 630D (5.5W x 19.3H x 24.8D)				
Weight kg (lb)	17 (44)				
Shipping dimensions mm (in)	770W x 590H x 410D (30.3W x 16.1H x 23.2D)				
Shipping weight kg (lb)	22 (49)				
Operating temp °C (°F)	15 to 35 (59 to 95)				
Inlet connection	1/4" Compression				
Outlet connection	1/8" Compression				
Certification	CE, FCC				

CONSUMABLES:

- DB-N-FIL004** COALESCENT FILTER AF20 WITH CARTRIDGE
- DB-10161** REPLACEMENT CARTRIDGE FOR COALESCENT FILTER AF20 (4 PIECES)

ORDERING INFORMATION (for best service, please call to discuss your application before placing your order).

HP PLUS 500	
DB-N2T-500-EU	220V/50Hz
DB-N2T-500-US	115V/60Hz

HP PLUS 750	
DB-N2T-750-EU	220V/50Hz
DB-N2T-750-US	115V/60Hz

HP PLUS 200 HC	
DB-N2T-200-O-EU	220V/50Hz
DB-N2T-200-O-US	115V/60Hz

HP PLUS 500 HC	
DB-N2T-500-O-EU	220V/50Hz
DB-N2T-500-O-US	115V/60Hz

HP PLUS 750 HC	
DB-N2T-750-O-EU	220V/50Hz
DB-N2T-750-O-US	115V/60Hz

HP PLUS 1300	
DB-N2T-1300-EU	220V/50Hz
DB-N2T-1300-US	115V/60Hz

HP PLUS 4000	
DB-N2T-4000-EU	220V/50Hz
DB-N2T-4000-US	115V/60Hz

HP PLUS 1300 HC	
DB-N2T-1300-O-EU	220V/50Hz
DB-N2T-1300-O-US	115V/60Hz

HP PLUS 4000 HC	
DB-N2T-4000-O-EU	220V/50Hz
DB-N2T-4000-O-US	115V/60Hz



HP PLUS RACK NITROGEN GENERATOR



FLOW RATE:
500 mL/min



PURITY:
>99.999%



PRESSURE:
5 barg (75 psig)



TECHNOLOGY:
Carbone Molecular Sieve



DESCRIPTION

The VICI DBS HP Plus Rack produces nitrogen by utilizing a combination of filtration and pressure swing adsorption (PSA) technology. Standard compressed air is filtered by high efficiency coalescing filters to remove all contaminants down to 5 micron. For ultra-sensitive applications, the 19" rack units also include the additional heated catalyst module to ensure hydrocarbons are removed to <0.1 ppm. The air then passes through two columns filled with a carbon molecular sieve (CMS) which removes O₂, CO₂, and moisture. These are desorbed to the atmosphere during the pressure swing cycle leaving a supply of ultra-pure nitrogen.



APPLICATIONS

ANALYZER APPLICATIONS

- Online GC-FID
- MUDD Logging
- Carrier gas and make up gas
- Total Hydrocarbon Analyzer (THA) fuel gas

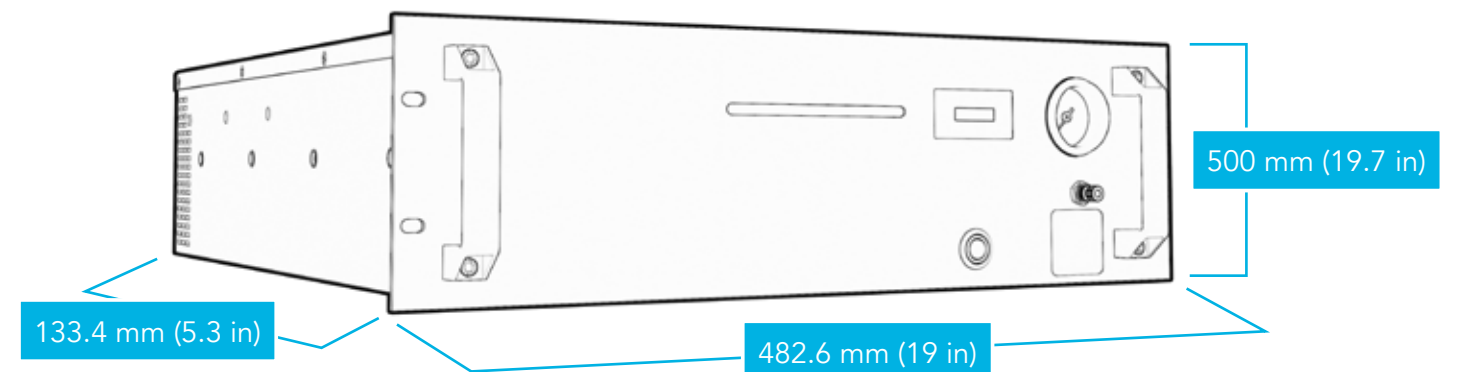

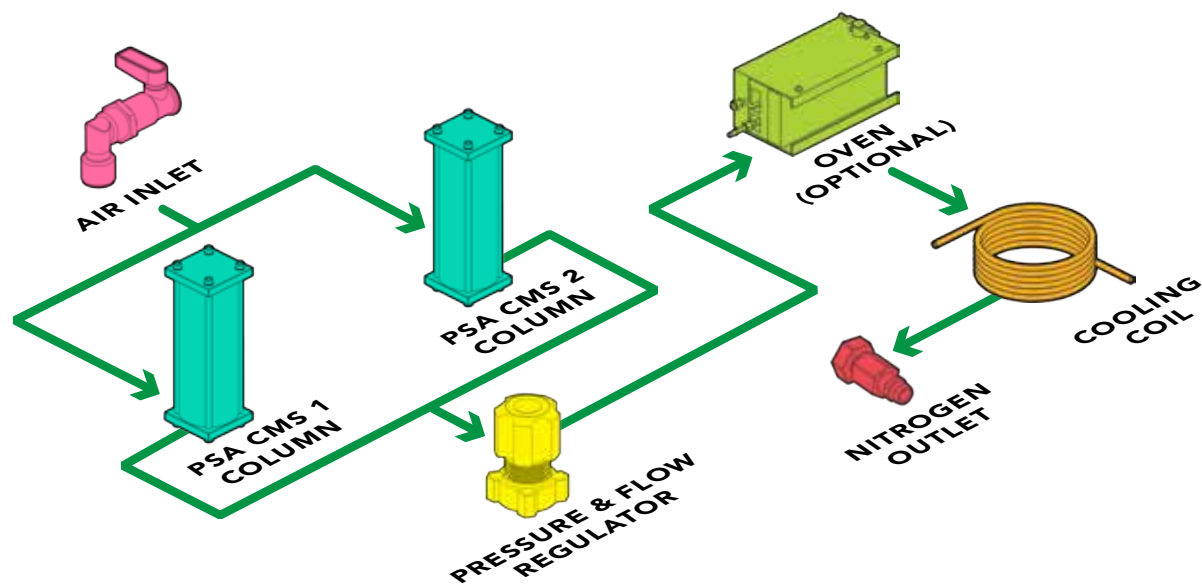

OPERATING DIAGRAM

Standard compressed air is filtered by high efficiency coalescing filters to remove all contaminants. For ultra-sensitive applications, the VICI DBS HP Plus Rack also includes an additional heated catalyst module to ensure hydrocarbon removal. The air then passes through two PSA columns that remove oxygen, carbon dioxide and water from compressed air. Thus resulting in a stream of ultra-pure nitrogen ideal for many analyzer applications.



UNIQUE BENEFITS

- Ideal for analyzer applications - stable baseline with increased sensitivity and repeatability
- Superior nitrogen purification with long life catalyst



MODELS & SPECS

	HP PLUS RACK 500
Flow mL/min	500
Purity	>99.999%
Hydrocarbon purity (measured as methane)	<0.1 ppm
Dew point °C (°F)	-50 (-58)
Outlet pressure barg (psig)	up to 5 (75)
Inlet pressure barg (psig)	7 to 10 (100 to 160)
Actual inlet air requirement litres - at 8 barg (116 psig)	11
Recommended compressor air inlet - at 8 barg (116 psig)	22
Pressure drop barg (psig)	1.5 (22)
Inlet air quality	Clean dry compressed air ISO8573-1:2010 Class 1.2.1
Technology	Carbon molecular sieve
Warm up time minutes	60
LED indicators	Power on/off, system ready, errors
Electrical supply	110-120V 60Hz / 220-240V 50Hz
Power consumption watts	270
Noise level	Minimal
Dimensions mm (in)	19" rack W x 3U H x 500D (19W x 5.25H x 19.68D)
Weight kg (lb)	10 (22)
Shipping dimensions mm (in)	720W x 375H x 565D (28.3W x 14.7H x 22.2D)
Shipping weight kg (lb)	14 (31)
Operating temp °C (°F)	15 to 35 (59 to 95)
Inlet connection	1/4" OD Swagelok or 6 mm OD rapid fitting
Outlet connection	1/8" OD Swagelok or 4 mm OD rapid fitting

CONSUMABLES:

- DB-N-FIL004** COALESCENT FILTER AF20 WITH CARTRIDGE
- DB-10161** REPLACEMENT CARTRIDGE FOR COALESCENT FILTER AF20 (4 PIECES)

ORDERING INFORMATION (for best service, please call to discuss your application before placing your order).

HP PLUS RACK 500

- DB-N2R-500-O-EU** 230-240V/50-60Hz
- DB-N2R-500-O-US** 100-110V/60Hz



ZERO AIR GENERATORS

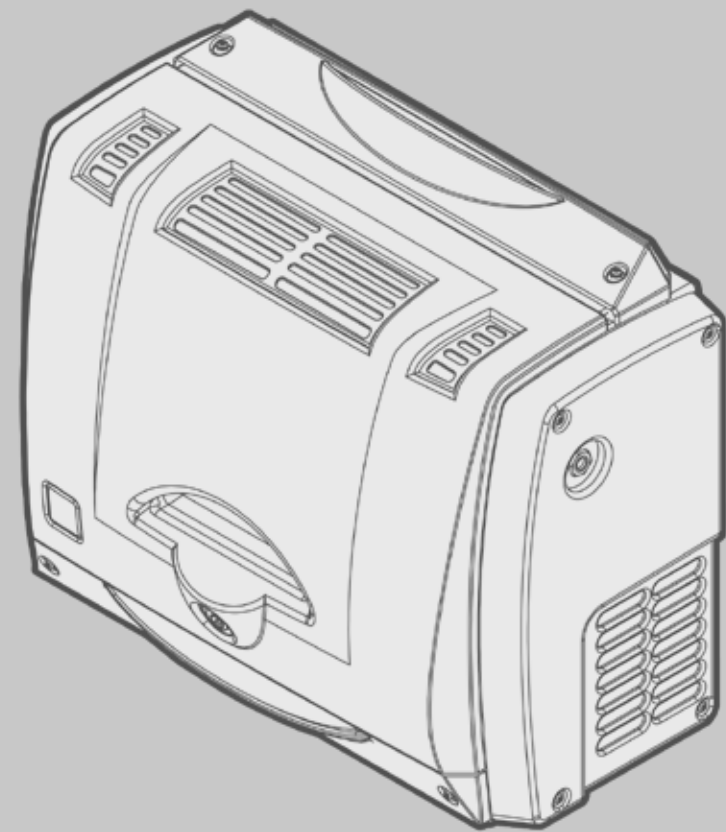
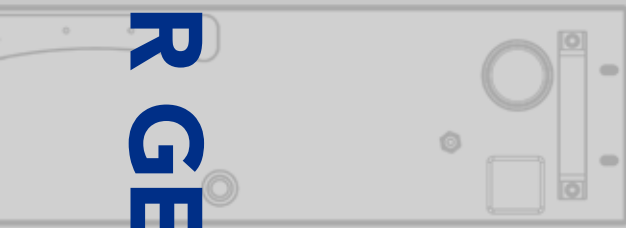

PRODUCT COMPARISON

	FLOW RATE	PURITY	PRESSURE - barg (psig)
GC PLUS 1500	1500 mL/min	<0.1 ppm	1 (15)
GC PLUS 3000	3000 mL/min	<0.1 ppm	1 (15)
GC PLUS 6000	6000 mL/min	<0.1 ppm	1 (15)
GC PLUS 15000	15000 mL/min	<0.1 ppm	1 (15)
GC PLUS 30000	30000 mL/min	<0.1 ppm	1 (15)
GC PLUS 1800 RACK	1800 mL/min	<0.1 ppm	1 (15)
GC PLUS 5000 RACK	5000 mL/min	<0.1 ppm	1 (15)
GC PLUS 10000 RACK	10000 mL/min	<0.1 ppm	1 (15)
GC PLUS 15000 RACK	15000 mL/min	<0.1 ppm	1 (15)
GT PLUS 1500	1500 mL/min	<0.1 ppm	1 (15)
GT PLUS 3000	3000 mL/min	<0.1 ppm	1 (15)
GT PLUS 6000	6000 mL/min	<0.1 ppm	1 (15)
GT PLUS 15000	15000 mL/min	<0.1 ppm	1 (15)
GT PLUS 30000	30000 mL/min	<0.1 ppm	1 (15)





GC PLUS ZERO AIR GENERATOR



FLOW RATE:
1500 to 30000 mL/min



PURITY:
<0.1 ppm



INLET PRESSURE:
4.5 to 10 barg (65 to 145 psig)



TECHNOLOGY:
Platinum Catalyst



APPLICATIONS

GC APPLICATIONS

- GC-FID oxidant gas
- GC-NPD gas
- GC-FPD gas

ANALYZER APPLICATIONS

- Total Hydrocarbon Analyzer (THA) detector gas

DESCRIPTION

The VICI DBS GC Zero Air Generator utilizes compressed air that is prefiltered to 5 microns and then purified using a state of the art combined heated catalyst module. The output zero grade air is free from total hydrocarbons to <0.1 ppm, making it ideal for all FID applications. This gas purity level (measured as methane) guarantees a low signal to noise ratio, ensuring a flat and stable GC baseline.

With no moving parts and silent operation, the generator is extremely reliable and ideal to be installed directly in the laboratory. With flow rates up to 30 L/min, one system can support up to 75 FIDs. With short payback time, minimal maintenance and operator attention they are an ideal addition to any GC laboratory.

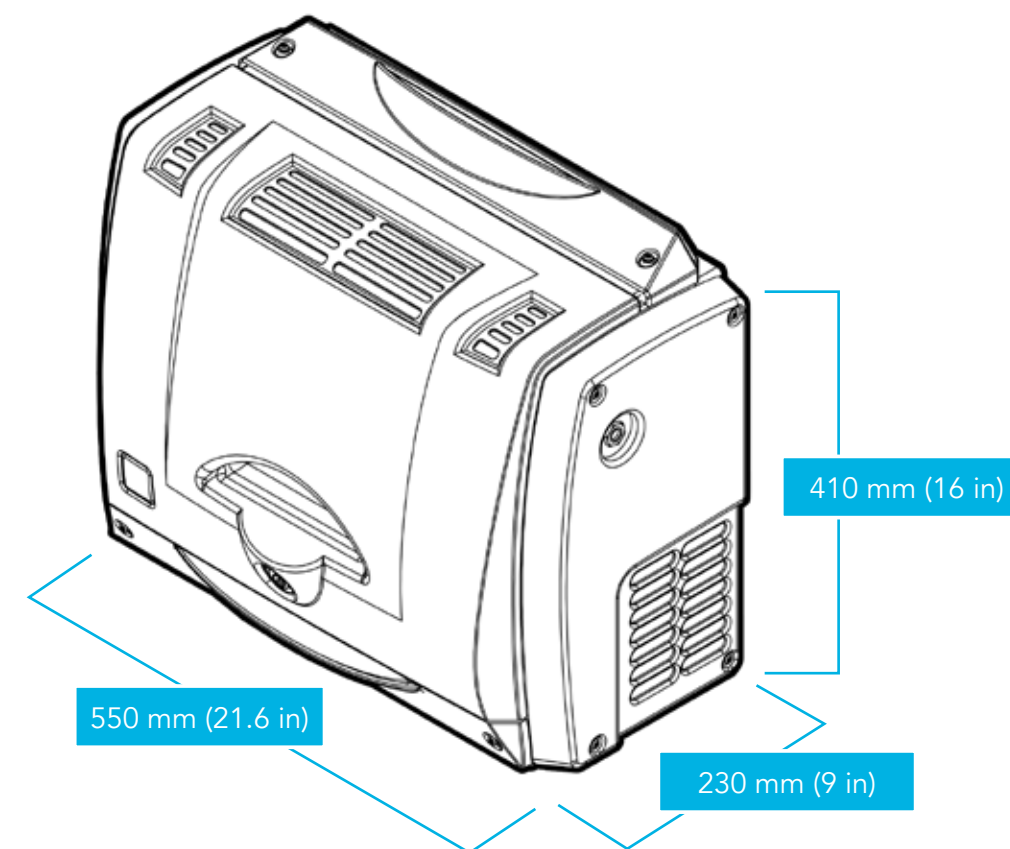

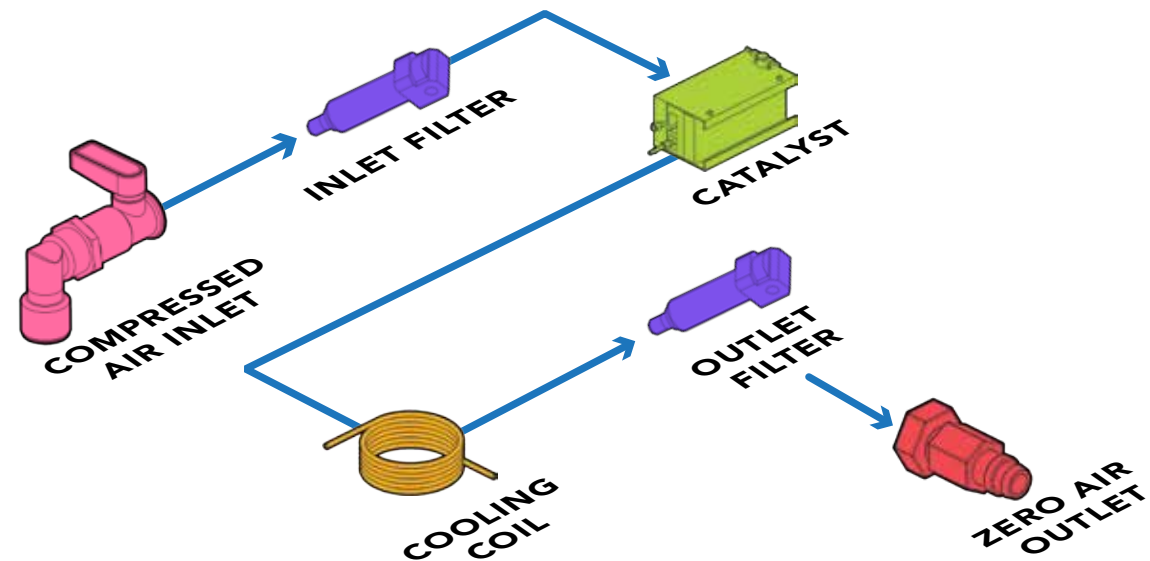

OPERATING DIAGRAM

Zero Air generators use three steps to transform ambient air into analytical grade air.

STEP 1: PRE-FILTRATION

The external oil-free compressor delivers air through a high-efficiency filter that removes any particles or aerosols which may damage the system. The filter has an automatic drain system and removes oil, water, and any other particles larger than 5 microns in size.

STEP 2: HC AND CO REMOVAL

The air leaving the filter enters a high-temperature platinum catalyzer, through which oxidation eliminates all hydrocarbon molecules down to <0.1 ppm.

STEP 3: FINAL FILTRATION

A high-efficiency polishing filter is used to prevent any kind of particles from entering the instrument.

MODELS & SPECS

	GC PLUS 1500	GC PLUS 3000	GC PLUS 6000	GC PLUS 15000	GC PLUS 30000
Flow mL/min	1500	3000	6000	15000	30000
Purity - hydrocarbons	<0.1 ppm				
Purity - CO	<0.1 ppm				
Inlet pressure barg (psig)	4.5 to 10 (65 to 145)				
Inlet air quality	Clean dry compressed air ISO8573-1:2010 Class 1.2.1				
Max outlet pressure barg (psig)	1 (15) drop from inlet				
Max HC in	100 ppm				
Max CO in	50 ppm				
Technology	Platinum catalyst				
LED indicators	Power on/off, system ready, errors				
Warm up time minutes	45				
Electrical supply	110-120V 60Hz / 220-240V 50Hz				
Power consumption watts	200	550	550	550	550
Dimensions mm (in)	550W x 410H x 230D (21.6W x 16H x 9D)				
Weight kg (lb)	9.5 (21)	11 (24)	11 (24)	12 (26.5)	13 (28.5)
Shipping dimensions mm (in)	650W x 390H x 560D (25.6W x 15.3H x 22D)				
Shipping weight kg (lb)	14 (31)	15 (33)	15 (33)	16 (35)	17 (37.5)
Operating temp °C (°F)	15 to 35 (59 to 95)				
Inlet connection	1/4" Compression				
Outlet connection	1/8" Compression				
Certification	CE, FCC, MET (UL and CSA compliant)				

CONSUMABLES:

- DB-N-CART001** REPLACEMENT CARTRIDGE FOR INLET FILTER
- DB-N-FIL001** FILTER HOUSING COMPLETE WITH FILTER CARTRIDGE (EXTERNAL)
- DB-N-FIL002** FILTER FOR ZERO AIR GENERATOR (INTERNAL)

ORDERING INFORMATION (for best service, please call to discuss your application before placing your order).

GC PLUS 1500

DB-NGC1500-EU 230-240V/50-60Hz
DB-NGC1500-US 100-110V/60Hz

GC PLUS 3000

DB-NGC3000-EU 230-240V/50-60Hz
DB-NGC3000-US 100-110V/60Hz

GC PLUS 6000

DB-NGC6000-EU 230-240V/50-60Hz
DB-NGC6000-US 100-110V/60Hz

GC PLUS 15000

DB-NGC15000-EU 230-240V/50-60Hz
DB-NGC15000-US 100-110V/60Hz

GC PLUS 30000

DB-NGC30000-EU 230-240V/50-60Hz
DB-NGC30000-US 100-110V/60Hz





GC PLUS RACK ZERO AIR GENERATOR



FLOW RATE:
1800 to 15000 mL/min



PURITY:
<0.1 ppm



INLET PRESSURE:
4.5 to 10 barg (65 to 145 psig)



TECHNOLOGY:
Platinum Catalyst



APPLICATIONS

ANALYZER APPLICATIONS

- Online GC-FID
- Mud logging
- Total Hydrocarbon Analyzer (THA) detector gas

DESCRIPTION

The VICI DBS GC Plus Rack Zero Air Generator utilizes compressed air that is prefiltered to 5 microns and then purified using a state of the art combined heated catalyst module. The output zero grade air is free from total hydrocarbons to <0.1 ppm, making it ideal for all FID applications. This purity level (measured as methane) produces a low signal to noise ratio, ensuring a flat and stable analyzer baseline.

With no moving parts and silent operation, the generator is extremely reliable and can be installed directly in the laboratory. With flow rates up to 15 L/min, one system can support up to 33 FIDs. With short payback time, minimal maintenance and operator attention they are an ideal addition to any analyzer application.

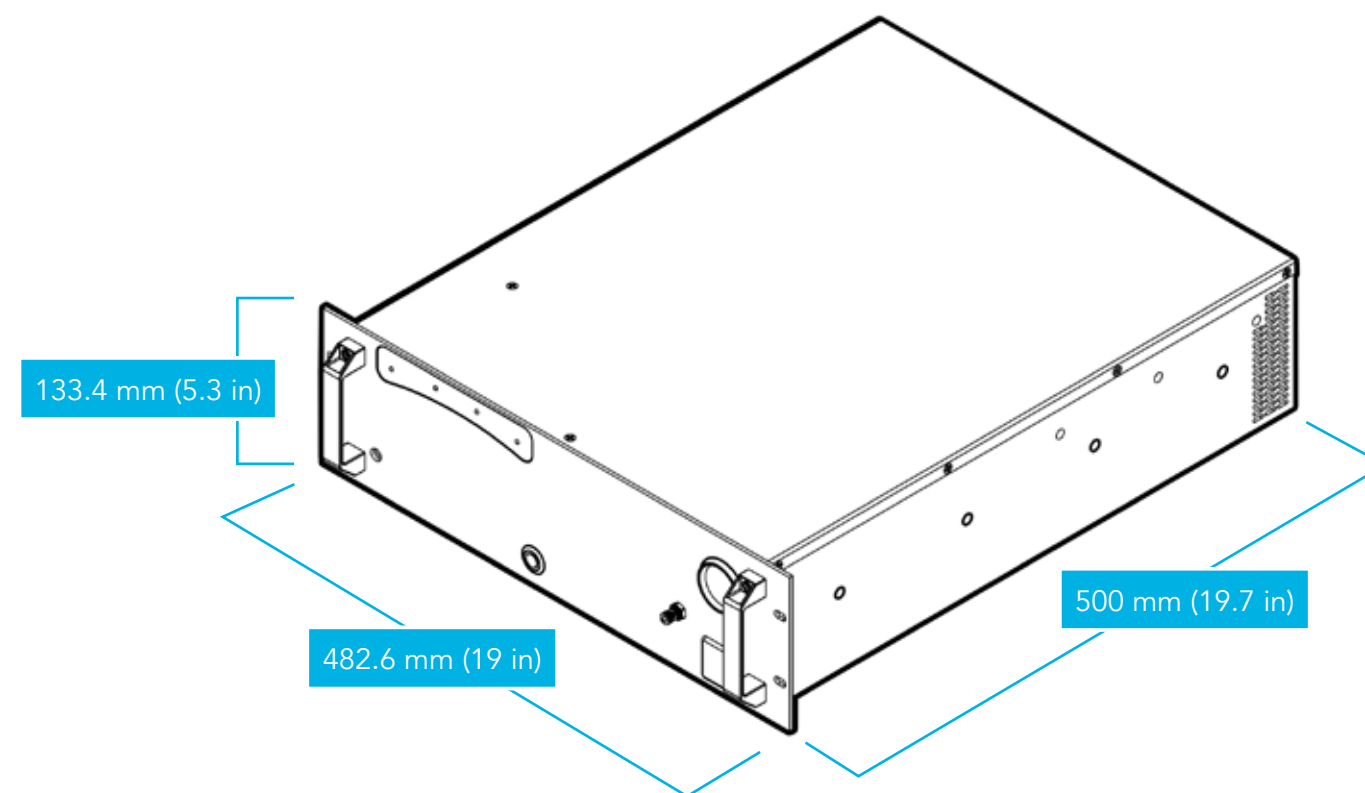

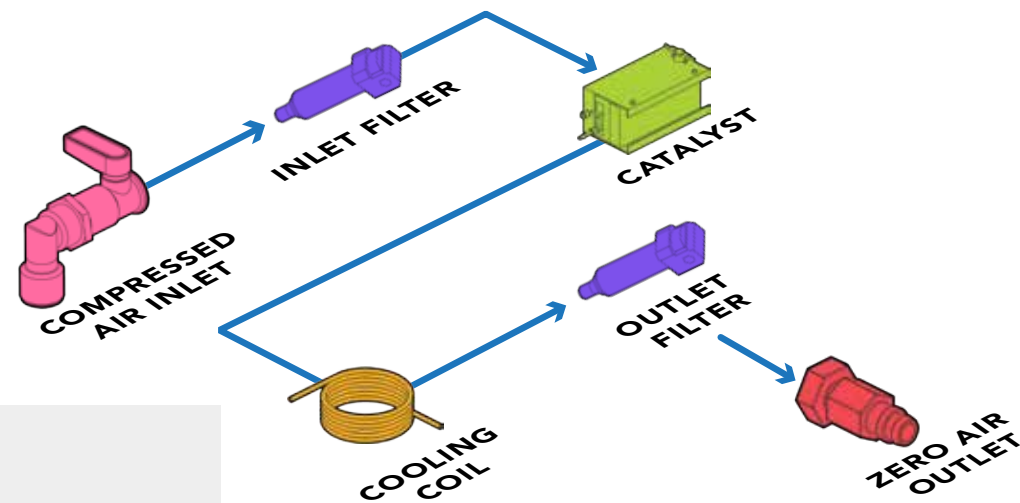

OPERATING DIAGRAM

Zero Air generators use three steps to transform ambient air into analytical zero-grade air.

STEP 1: PRE-FILTRATION

The external oil-free compressor delivers air through a high-efficiency filter that removes any aerosols and particles that may damage the system. The filter has an automatic drain system and removes oil, water, and any other particles larger than 5 microns in size.

STEP 2: HC AND CO REMOVAL

The air leaving the filter enters a high-temperature platinum catalyzer, which through oxidation eliminates all hydrocarbon molecules down to <0.1 ppm.

STEP 3: FINAL FILTRATION

A high-efficiency polishing filter is used to prevent any kind of particles from entering the instrument.



MODELS & SPECS

	GC PLUS 1800 RACK	GC PLUS 5000 RACK	GC PLUS 10000 RACK	GC PLUS 15000 RACK
Flow mL/min*	1800	5000	10000	15000
Purity - hydrocarbons	<0.1 ppm			
Purity - CO	<0.1 ppm			
Inlet pressure barg (psig)	4.5 to 10 (65 to 145)			
Inlet air quality	Clean dry compressed air ISO8573-1:2010 Class 1.2.1			
Max outlet pressure barg (psig)	1 (15) drop from inlet			
Max HC in	100 ppm			
Max CO in	50 ppm			
Technology	Platinum catalyst			
LED indicators	Power on/off, system ready, errors			
Warm up time minutes	45			
Electrical supply	110-120V 60Hz / 220-240V 50Hz			
Power consumption watts	200	550	550	550
Dimensions mm (in)	19" rack W x 3U H x 500D (19W x 5.25H x 19.68D)			
Weight kg (lb)	15 (33)			
Shipping dimensions mm (in)	720W x 375H x 565D (28.3W x 14.7H x 22.2D)			
Shipping weight kg (lb)	19 (42)			
Operating temp °C (°F)	15 to 35 (59 to 95)			
Inlet connection	1/4" Compression			
Outlet connection	1/8" Compression			
Certification	CE, FCC, MET (UL and CSA compliant)			

*1.8 and 5 L/min versions also available with integral compressor

CONSUMABLES:

- DB-RH200-013** COALESCENT FILTER AF10 WITH CARTRIDGE
- DB-RH200-017** REPLACEMENT CARTRIDGE FOR COALESCENT FILTER AF20

ORDERING INFORMATION (for best service, please call to discuss your application before placing your order).

GC PLUS 1800 RACK

- DB-RGC1800-EU** 230-240V/50-60Hz
- DB-RGC1800-US** 100-110V/60Hz

GC PLUS 5000 RACK

- DB-RGC5000-EU** 230-240V/50-60Hz
- DB-RGC5000-US** 100-110V/60Hz

GC PLUS 10000 RACK

- DB-RGC10000-EU** 230-240V/50-60Hz
- DB-RGC10000-US** 100-110V/60Hz

GC PLUS 15000 RACK

- DB-RGC15000-EU** 230-240V/50-60Hz
- DB-RGC15000-US** 100-110V/60Hz



GT PLUS ULTRA ZERO AIR GENERATOR



FLOW RATE:
1500 to 30000 mL/min



PURITY:
<0.1 ppm



INLET PRESSURE:
4.5 to 10 barg (65 to 145 psig)



TECHNOLOGY:
Platinum Catalyst



DESCRIPTION

The VICI DBS GT Plus Ultra Zero Air Generator utilizes compressed air that is purified using a five-step conditioning process. The output zero grade air is free from THC, CO, CO₂, NO_x, SO_x, Ozone, and water vapor, making it ideal for all analyzer, TOC, and specialist detector applications.

The generator is extremely reliable and easily installed directly in the laboratory or online. With flow rates up to 30 L/min, one system can support multiple analyzers. With short payback times, minimal maintenance and operator attention they are an ideal addition to provide gas to your analyzer.



APPLICATIONS

ANALYZER APPLICATIONS

- CEM continuous emissions monitoring
- CO₂ Analyzers
- Emissions Analyzers
- Online and Laboratory TOC
- Stack Gas Sampler
- Online and Laboratory FT-IR

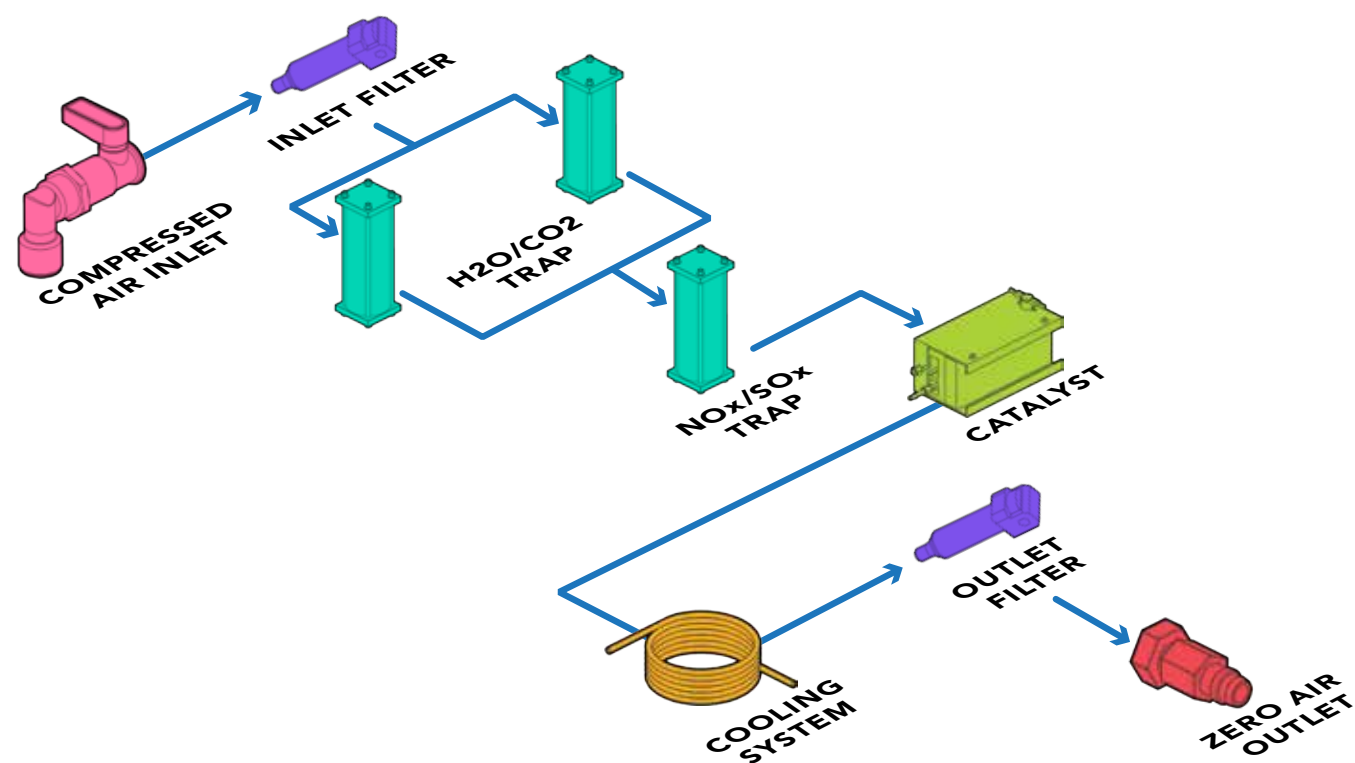

UNIQUE FEATURES

- Produces a continuous supply of dry ultra zero grade air
- Purity: Free from THC, CO, CO₂, O₃, NO_x & SO_x
- Proprietary platinum catalyst technology



UNIQUE BENEFITS

- Low pressure relative to cylinders
- Superior air purification with long life catalyst technology

OPERATING DIAGRAM

Ultra-Zero Air generators use five steps to transform ambient air into analytical grade air.

STEP 1: PRE-FILTRATION

The external air supply is prefiltered by high efficiency coalescing filters to remove water, oil, and particulate.

STEP 2: DRYING & TRAPPING

The self-regenerative PSA drying module removes water vapor and CO₂.

STEP 3: NO_x, SO_x & O₃

A unique, specifically designed scrubber removes NO_x & SO_x and Ozone.

STEP 4: HC & CO TRAPPING

The air leaving the filter enters a high-temperature platinum catalyzer, which through oxidation eliminates THC and CO.

STEP 5: FINAL FILTRATION

A high-efficiency polishing filter is used to ensure the exit zero air is free from all particulate.



MODELS & SPECS	GT PLUS ULTRA 1500	GT PLUS ULTRA 3000	GT PLUS ULTRA 6000	GT PLUS ULTRA 15000	GT PLUS ULTRA 30000
Flow mL/min	1500	3000	6000	15000	30000
Purity - hydrocarbons	<0.1 ppm				
Purity - CO	<0.1 ppm				
Purity - CO ₂	<5 ppm				
Purity - NO _x	<0.1 ppm				
Purity - SO _x	<0.1 ppm				
Purity - O ₃	<0.1 ppm				
Dew point °C (°F)	-50 (-58)				
Inlet pressure barg (psig)	4.5 to 10 (65 to 145)				
Outlet pressure barg (psig)	1 (15) drop from inlet				
Inlet air quality	Clean dry compressed air ISO8573-1:2010 Class 1.2.1				
Max HC in	100 ppm				
Max CO in	50 ppm				
Technology	Platinum catalyst				
LED indicators	Power on/off, system ready, errors				
Warm up time minutes	45				
Electrical supply	110-120V 60Hz / 220-240V 50Hz				
Power consumption watts	220	565	565	565	565
Dimensions mm (in)	550W x 410H x 230D (21.6W x 16H x 9D)			630W x 470H x 310D (24.8W x 18.5H x 12.2D)	
Weight kg (lb)	10 (22)	15 (33)	15 (33)	25.5 (56)	25.5 (56)
Shipping dimensions mm (in)	650W x 390H x 560D (25.6W x 15.3H x 22D)				
Shipping weight kg (lb)	14 (31)	19 (42)	19 (42)	30 (66)	30 (66)
Operating temp °C (°F)	15 to 35 (59 to 95)				
Inlet connection	1/4" Compression				
Outlet connection	1/8" Compression				
Certification	CE, FCC, MET (UL and CSA compliant)				

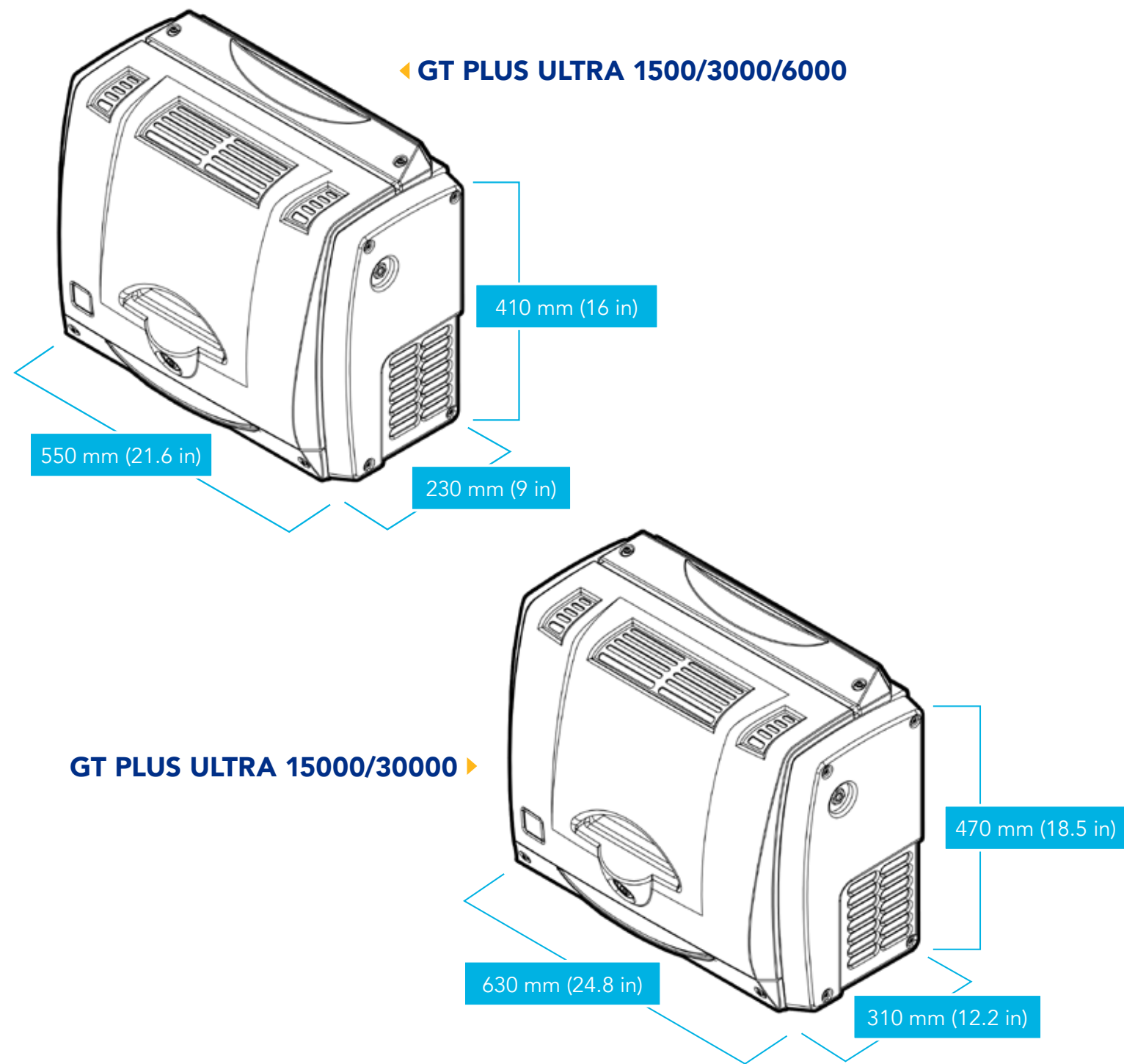

CONSUMABLES:

- DB-N-CART001** REPLACEMENT CARTRIDGE FOR INLET FILTER
- DB-N-FIL001** FILTER HOUSING COMPLETE WITH FILTER CARTRIDGE (EXTERNAL)
- DB-N-FIL002** FILTER FOR ZERO AIR GENERATOR (INTERNAL)
- DB-N-CART001** REPLACEMENT CARTRIDGE FOR INLET FILTER
- DB-N-FIL001** FILTER HOUSING COMPLETE WITH FILTER CARTRIDGE (EXTERNAL)
- DB-N-FIL002** FILTER FOR ZERO AIR GENERATOR (INTERNAL)

ORDERING INFORMATION (for best service, please call to discuss your application before placing your order).

GT PLUS ULTRA 1500

DB-NGT1500-EU 230-240V/50-60Hz
DB-NGT1500-US 100-110V/60Hz

GT PLUS ULTRA 3000

DB-NGT3000-EU 230-240V/50-60Hz
DB-NGT3000-US 100-110V/60Hz

GT PLUS ULTRA 6000

DB-NGT6000-EU 230-240V/50-60Hz
DB-NGT6000-US 100-110V/60Hz

GT PLUS ULTRA 15000

DB-NGT15000-EU 230-240V/50-60Hz
DB-NGT15000-US 100-110V/60Hz

GT PLUS ULTRA 30000

DB-NGT30000-EU 230-240V/50-60Hz
DB-NGT30000-US 100-110V/60Hz



ACCESSORIES

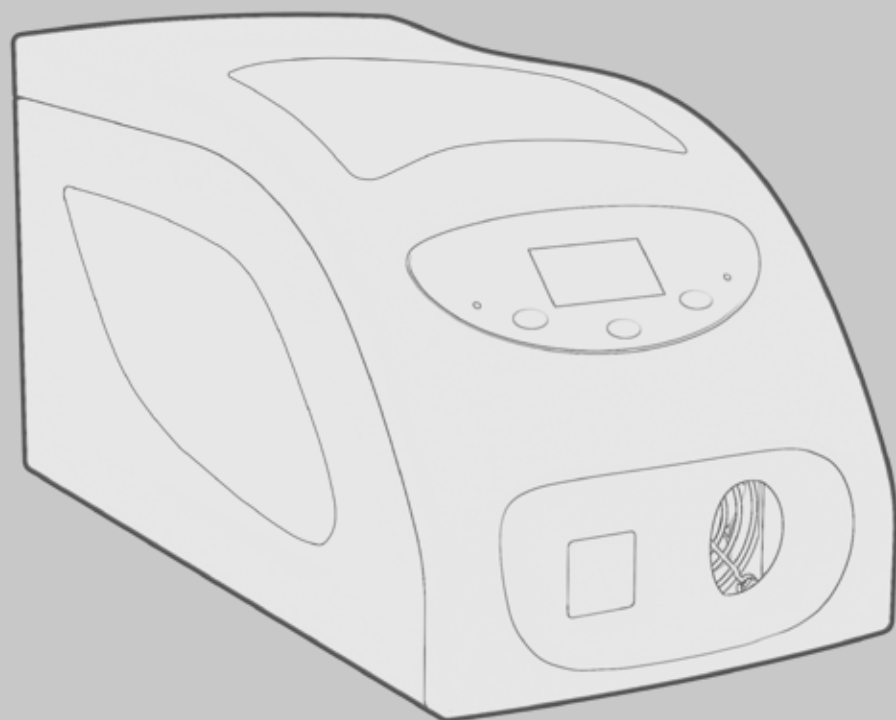

VICI DBS works alongside the customer in all phases of development of custom temperature controllers, from defining the required specifications to testing of final prototypes. The result is a high-quality and reliable temperature control accessory to operate as part of the instrument manufacturer's system. Indeed, as well as being customized in terms of colors, logos and size to fit with the instrument line, all DBS temperature controllers feature a built-in RS232 serial interface, allowing the units to be controlled within the manufacturer's software package.

CUSTOMIZATION

VICI DBS can customize our Peltier accessories to customer specifications.

ELECTRICAL MANAGING STATION

Customer to provide digital files of logo, as well as front and back labels.

VICI DBS will install labels as requested.

Custom Labeling Option:

- 35 mm x 35 mm (1.38" x 1.38") brand logo on front



PELTIER POWERED CELL HOLDER

Customer to provide cell holder/s for the cuvettes.

VICI DBS will devise a method of integrating the Peltier elements in the cell holder, ensuring that it functions the way the customer specifies (cool down and/or heat the cell holder, including also a possible magnetic stirring system).

Cell holders Cooling Options:

- Water-cooled
- Air-cooled

Cell Holder Cell Options:

- Single cell
- Double cell
- Multi-position cell

PCB 1500W PELTIER CRYOBATH

DESCRIPTION

Our accurate Peltier temperature controllers feature a wide temperature control range of 20 to 60°C (68 to 140°F) and can be made to accompany a variety of cell holder configurations (single cell, 1x1, 6x6, etc.). It is suitable for all water-thermostated cuvette holders (not included). The PCB 1500W includes an internal Peltier block for either heating or cooling of the circulating water.



BENEFITS

- User-friendly interface
- Digital display
- Local or remote control
- Dual voltage settings (110V/220V)



APPLICATIONS

SPECTROSCOPY SAMPLE COOLING AND HEATING

- Raman
- IR
- UV/VIS
- UV Fluorescence



PCB 1500 PLUS & HIGH PERFORMANCE PELTIER CRYOBATH

DESCRIPTION

The PCB 1500 Plus Peltier Cryobath is a Peltier-controlled external water re-circulator ideal for all thermostatic cell holders. As a stand-alone external accessory, it requires no electronic or physical modifications to the cell holders. The principal feature of this device is that the water is heated and cooled using Peltier elements, allowing a very wide temperature range as well as providing excellent temperature accuracy. In addition, heating and cooling ramps can be programmed locally or remotely (remote software not included). The PCB 1500 Plus requires a VICI DBS cuvette holder (available upon request). The PCB 1500 High Performance is suitable for all water-thermostated cuvette holders (not included).

The PCB Plus circulates water at ambient temperature. Heating and cooling occur in the cuvette cell holder via the PCB Plus controlled Peltier.



UNIQUE BENEFITS

- Wide temperature range, from 0 to 100°C (32 to 230°F)
- Excellent temperature accuracy



APPLICATIONS

SPECTROSCOPY SAMPLE COOLING AND HEATING

- Raman
- IR
- UV/VIS
- UV Fluorescence





OPTIONS

- Remote software
- Cuvette Holder: Available upon request. Wide range of layouts (single or multiple positions) and specific for the analytical instrument of the customer. Possibility of magnetic stirring, Peltier effect thermic control, and over-heating protection operated connecting the cell holder to the PCB unit.

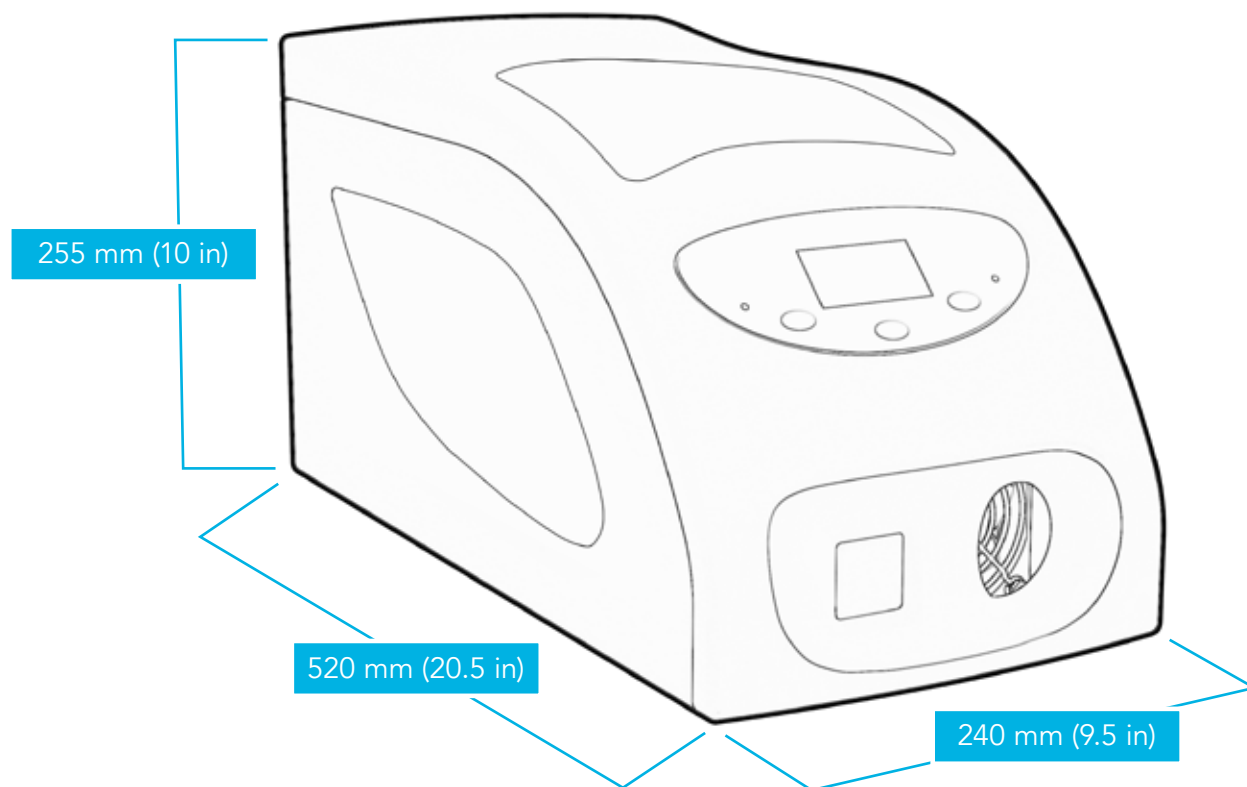

MODELS & SPECS	PCB 1500W	PCB 1500 PLUS	PCB 1500 HIGH PERFORMANCE
Operating temp °C (°F)	20 to 60 (68 to 140)	0 to 110 (32 to 230)	0 to 110 (32 to 230)
Temperature Accuracy °C (°F)	+/- 0.1 (0.18)		
Reproducibility	+/- 0.5 (0.9)		
Managing Peltier Cell Directly	No	Yes (single or multiple)	
Interface	RS-232C or USB		
Display	Digital		
LED indicators	Power on/off, system ready, errors		
Electrical supply	220-240V 50-60Hz / 115-120V 50-60Hz		
Power consumption watts	160		
Dimensions mm (in)	240W x 255H x 520D (9.5W x 10H x 20.5D)	240W x 255H x 520D (9.5W x 10H x 20.5D)	240W x 255H x 520D (9.5W x 10H x 20.5D)
Weight kg (lb)	10 (22)	15 (33)	25.5 (56)
Shipping dimensions mm (in)	330W x 390H x 595D (13W x 15.4H x 23.4D)		
Shipping weight kg (lb)	14 (31)	19 (42)	30 (66)
Inlet connection	Rapid water fitting PMCD female 1/8"		
Outlet connection	Rapid water fitting PMCD female 1/8"		
Certification	CE, FCC, MET (UL and CSA compliant)		

ORDERING INFORMATION (for best service, please call to discuss your application before placing your order).

PCB 1500W

DB-PCB-1500-EU 220-240V/50-60Hz
DB-NGT1500-US 115-120V/50-60Hz

PCB 1500 PLUS

DB-PCB-PLUS-EU 220-240V/50-60Hz
DB-PCB-PLUS-US 115-120V/50-60Hz

PCB 1500 HIGH PERFORMANCE

DB-PCB-HP-EU 220-240V/50-60Hz
DB-PCB-HP-US 115-120V/50-60Hz

YOUR DIRECT CONTACT:

VICI | DBS[®]
www.vicidbs.com